

# *imtra*<sup>®</sup>

C O R P O R A T I O N

## A N C H O R I N G   S Y S T E M S



# T A B L E O F C O N T E N T S

	INTRODUCTION	3
■	THE BASICS OF ANCHORING What you need to know about installing an anchoring system	4
■	HOW TO SELECT A WINDLASS A guide to choosing the windlass that's best for your needs	6
■	LOFRANS WINDLASSES	8
	Vertical Electric Windlasses	10
	Horizontal Electric Windlasses	16
	Manual Windlass	23
	Vertical Capstans	23
■	MUIR WINDLASSES	24
	Vertical Electric Windlasses	26
	Mega Yacht Windlasses	32
	Manual Windlass	34
	Drum Winches	35
	Horizontal Electric Windlasses	36
■	SWITCHGEAR	40
	Footswitches	40
	Control Boxes & Breakers	41
	Controls	42
	Handheld Remote Controls	42
■	ANCHOR CHAIN & RODES	44
■	ACCESSORIES	46
■	ANCHOR ROLLERS	48
■	REFERENCE GUIDE	50





## Your source for complete anchoring systems.

When you choose Imtra for your anchoring solutions, you can relax and enjoy impeccable performance, superior reliability and total peace of mind. At each step, Imtra provides you with the product selection, expertise and customer support that make all the difference.

We start by searching the world for the very best products, including windlasses from Lofrans and Muir, two brands recognized by boatbuilders for their quality and innovative engineering. In addition to windlasses, we offer a full range of switchgear and accessories to complete your system.



For more than 65 years, Imtra has built a solid reputation as a company that understands the marine industry. Our deep knowledge of marine systems allows us to provide customized solutions that go beyond standard installations to give you the best performance for your specific boating needs. We back up all of our products with expert technical support, prompt delivery and a focus on individual customer service that's unmatched in the industry. To get started, please contact Imtra at 508-995-7000 or visit our website at [www.imtra.com](http://www.imtra.com).

For more than 65 years, Imtra has built a solid reputation as a company that understands the marine industry. Our deep knowledge of marine systems allows us to provide customized solutions that go beyond standard installations to give you the best



**imtra**  
CORPORATION  
[www.imtra.com](http://www.imtra.com)

Imtra Corporation, 30 Samuel Barnet Boulevard, New Bedford, MA 02745 Ph: 508.995.7000 Email: [info@imtra.com](mailto:info@imtra.com)

## THE BASICS OF ANCHORING

### What you need to know about installing an anchoring system.

With so much investment riding on your boat's anchoring system, it's essential to understand the basics of anchoring and the components you will need to complete a fully-integrated, high-performance system. A well thought-out anchoring system will help make boating easier, safer, and more enjoyable for years to come.

Which system is best for you? Your choice depends on the size and type of your boat, as well as the anchoring conditions you typically encounter. Imtra has the extensive product selection you need for a customized solution. Individually, these are the top brands sought by boatbuilders and yachtsmen around the world. Together, these products function seamlessly as a comprehensive anchoring system.

#### Windlasses

A **windlass** is the backbone of any anchoring system. Imtra offers the complete range of windlasses from Lofrans [p.8](#) and Muir [p.24](#), the world's leaders in anchor windlasses. Choose from horizontal, vertical, electric (DC or AC), hydraulic or manual – every variation to meet your specific needs.

#### Footswitches

[p.40](#)

Most windlasses are operated by these simple **deck-mounted switches**. High-amperage models can operate a windlass without a control box. Low-amperage models make a good choice for customers using a control box who want a small deck cutout or multiple control stations.

#### Control Boxes

[p.41](#)

These watertight **control boxes** contain solenoids that interpret signals from the windlass operator (via footswitches, toggles, remote panels or handhelds). Pre-wired and fully sealed, they feature easy-access terminals for DC electric and control cables.

#### Circuit Breakers

[p.41](#)

**Circuit breakers** are needed to protect the motor and wiring from electrical overload. Wiring should be sized to carry the full motor current and the circuit breakers should be sized based on the current carrying capacity of the wire. They also act as a safety shut-off for the system. We offer different amp-rated breakers to match the wattage of the motor. Typically, the breaker's amperage rating is equal to 10% of the motor wattage for 12vdc systems (5% for 24vdc).

#### SYSTEM OVERVIEW

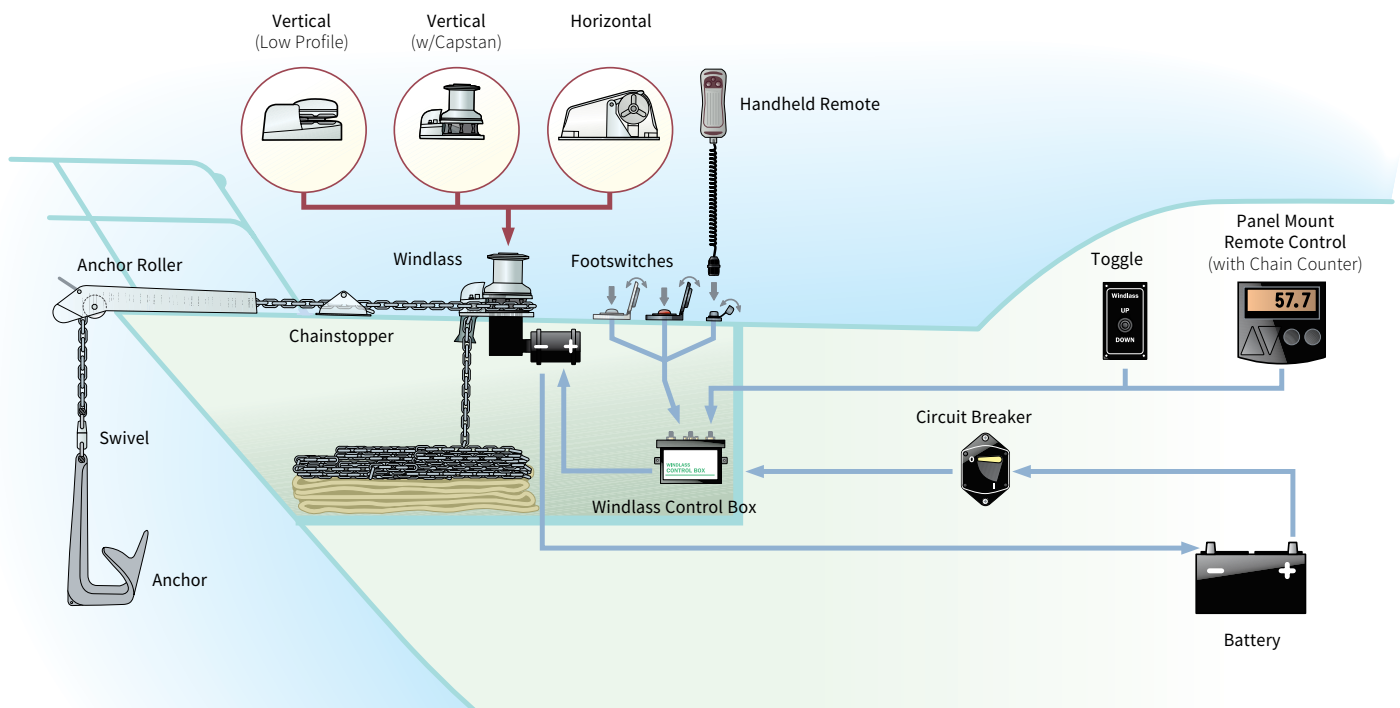




Photo: Mag Bay Yachts

### Toggles and Panel Controls

p.41

Many boats offer **control panels** to operate a windlass from the helm station. Whether you choose a simple up/down toggle or a full-function, chain-counting panel-mount control system, Imtra has a control for you.

### Handheld Remotes

p.42

Add-ons like **handheld remotes** can make operating your windlass so much easier. Fully watertight, these convenient controls allow you to move about the boat while controlling the windlass. They are even available wired or wireless and some with built-in chain-counters and LED flashlights!

### Anchor Rodes

p.44

Often overlooked in the design of anchoring systems, the **anchor rode** plays a more critical role than some may realize. Selecting the proper fit, material and length/size combination will ensure your windlass will payout and retrieve your anchor quickly, reliably and safely. Created to fit your own specifications, the options are endless. Available in stainless steel, HT, or BBB chain spliced expertly to high quality anchor line.

### Chainstoppers

p.46

A must-have for boaters running all-chain rodes, a **chainstopper** takes the load off the windlass and puts it safely on the boat when anchored. Our basic stainless steel version suits most applications, though more elegant models are available for those desiring a more finished appearance. Larger yachts can even consider models with devil's claws to tightly secure the anchor into its roller while underway.

### Anchor Rollers

p.48

Our wide range of **anchor rollers** will protect your yacht and stow your anchor securely. All Imtra rollers offer Delrin® wheels for added durability.



Photo: MJM

## HOW TO SELECT A WINDLASS

### The right anchor windlass makes all the difference.

The anchor windlass on your boat allows you to handle even the most difficult anchoring situations safely and with complete peace of mind. Choosing the right size and type of windlass for your vessel is the key to trouble-free boating.



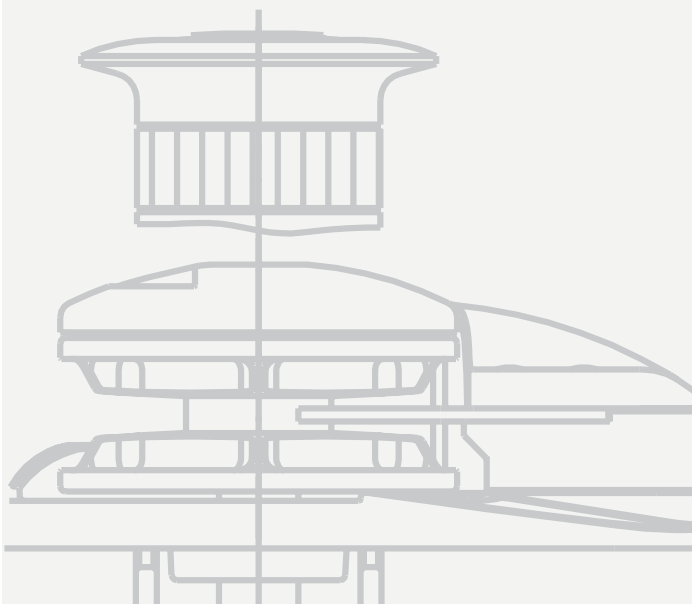
Photo: Duffy Yachts

Several factors play an important role when selecting a windlass: vessel type and size, displacement, anchor and chain size, and the anchoring environment.

The range of available models includes horizontal and vertical, manual, electric or hydraulic and

chain or combination rope/chain management.

Imtra has the technical expertise and extensive product selection to make your decision process easier. To help you get started, we offer the following handy guide.



### Which windlass is the best for



#### Manual, Electric or Hydraulic

With a **Manual** windlass, you provide the energy. Manuals are less expensive, easier to install and require neither the wiring nor the plumbing of electric and hydraulic windlasses.

**Electric** windlasses are by far the most popular. They supply generous lifting power to make the retrieval of your anchor and rode a simple task of pressing a footswitch or pushing a button. They are compact in size and usually can be operated off the boat's existing electrical system.

**Hydraulic** windlasses are extremely strong and efficient. They require a central hydraulic system within the yacht to power them. For this reason, they are usually fitted only on larger yachts with an existing hydraulic system that would control other equipment on the boat.

#### Rope/Chain or All Chain

Today, most people fit combination rope/chain anchor rodes. These rodes combine a mid-length piece of chain (10-50') spliced to a high-quality 3-strand anchor line of a length selected by the owner. Most vertical windlasses are now designed to retrieve these combination rodes around a single gypsy or chainwheel. Some horizontals, typically for smaller boats, can also accept combination rope/chain rodes.

The primary advantage of **rope/chain** rodes is a savings in weight in the bow of the boat. The nylon anchor line also gives an element of elasticity to the rode that can be more comfortable at anchor in heavy weather.

**Chain only** rodes are much easier to retrieve reliably for all windlasses. Chain does not kink as anchor line can, therefore you avoid "hockles" that can sometimes slow the retrieval process. Chain is also stronger and usually allows the anchor rode to be set with less "scope" than a rope/chain rode.



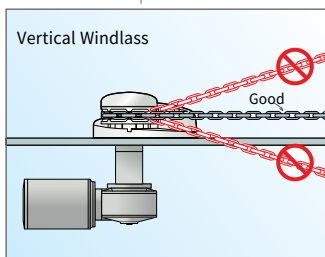
Photo: Krogen Express

my boat? Here are the most important things to consider before you buy.

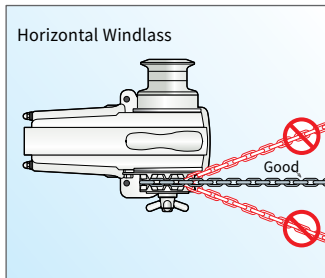
**Vertical or Horizontal**

**Vertical** windlasses place the chainwheel on a vertical drive shaft above the gearbox and motor, which are mounted below deck. The “topworks” can thus be lower in profile. Vertical windlasses often retrieve combination rope/chain rodes. The anchor rode should lead to the windlass parallel with the plane of the chainwheel for best results. The lead should be within 5 degrees of level to the chainwheel.

**Horizontal** models mount the chainwheel and capstan on either side of the on-deck housing which usually contains both the motor and gearbox. Horizontals make very good choices for boats with little space below deck to mount the motor and gearbox. Most horizontals retrieve rope and chain separately. For this reason, most owners of horizontals choose all-chain rodes. The lead of the anchor rode on the horizontal should also be in line with the plane of the chainwheel.



The anchor chain should have a straight entry to the winch, not entering from a vertical angle.



The anchor chain should have a straight entry to the winch, not entering from Port or Starboard.

**Sizing Considerations**

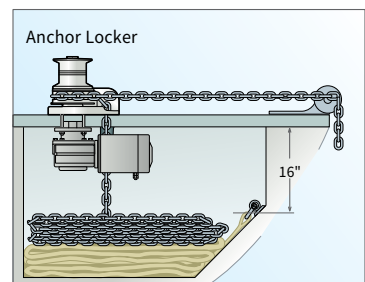
The windlass is intended to lift the anchor and ground tackle, not to pull or drag the boat. A typical rule of thumb is to take the total weight of your anchor and complete anchor rode and multiply that by a factor of three. This number should be less than the power rating of the windlass. On the introductory pages for each windlass brand, we include charts of the typical boat sizes for each model.

Use these charts to get an idea of what size is right for you. We also strongly recommend that you consult marine professionals to determine what size windlass is right for your boat. You can also contact Imtra at 508-995-7000 to discuss your individual requirements.

**Mounting Locations**

With both horizontal and vertical models, a windlass should normally be mounted on the yacht’s centerline with the chain in close alignment to a line drawn from the chainwheel through the bow roller (or chock) to straight ahead in the water. It is important, especially for combination rodes, to locate your windlass so that, as rope is stripped from chain-wheel or drum, it can “fall” directly into the rope locker.

The location and depth of an anchor locker are important elements in a windlass installation. When the rode is in the anchor locker, the top of the anchor rode should be a minimum of 16" below the underside of the deck. The windlass should also be positioned so the chain and rope feed through the windlass deck plate or hawsepipe directly into the deepest section of the anchor locker.



**Installation**

For your convenience, Imtra provides easy access to technical information on windlass installation at our website. Go to [www.imtra.com](http://www.imtra.com) and simply download the files you need, including owners manuals, parts diagrams, dimensional drawings and more. If you need technical advice or other information, our knowledgeable staff is ready to help at 508-995-7000.



Photo: Hunter Yachts

HOW TO SELECT A WINDLASS

**LOFRANS WINDLASSES**



**Lofrans – a worldwide reputation for engineering excellence for three generations.**

Lofrans was founded in 1966 in Monza, Italy, with a determined focus: to design and manufacture the highest quality anchor windlasses at competitive pricing. Over the years, this commitment, along with technical expertise and innovation, has led to impressive results. Today, Lofrans is a world leader in the manufacturing of inshore and offshore anchor windlasses. A large base of customers – from yachtmen to prominent boat builders – have made Lofrans their windlass of choice.

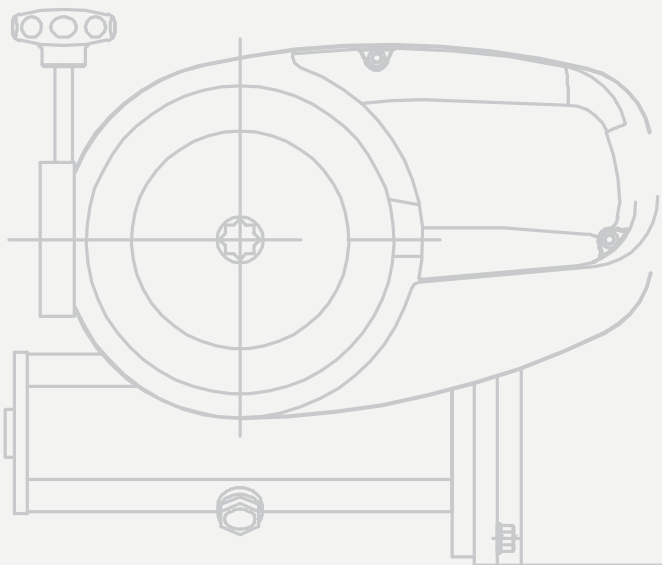


Photo: Mag Bay Yachts

**What sets Lofrans apart.**

Lofrans is recognized throughout the boating industry for quality engineering and rugged durability. Lofrans windlasses stand the test of time, providing years of exceptional performance for owners of boats from 20' to 80' and more.

**Purpose-built for marine use.**

All the components of a Lofrans windlass are designed and manufactured specifically for the harsh marine environment. The mainshafts are made of AISI 431 stainless steel for durability. Vertical topworks are cast of marine-grade bronze and chrome-plated to a mirror finish. Horizontal housings are made of a special aluminum alloy, polished and then anodized. Wormwheels are alloy bronze and wormscrews are 38NCD4 stainless steel.



Hot-forged components are supplied with most models. Hot-forging provides high mechanical strength, better surface conditions, and a more compact molecular structure than traditional cast parts.

Gearboxes are corrosion-resistant anodized aluminum and have ratios between 1:50 and 1:75 for the ideal balance of performance and speed. Lofrans electric motors are IP65 for marine use. Most are series-wound, which produces an initial starting torque that provides a critical advantage over permanent magnet motors.

**The latest in engineering and design.**

Through innovative engineering and advanced design, Lofrans maintains its leadership position in the market. Robust construction has made our solid horizontal models popular for heavy-use vessels such as charter boats, world cruisers and live-aboards.

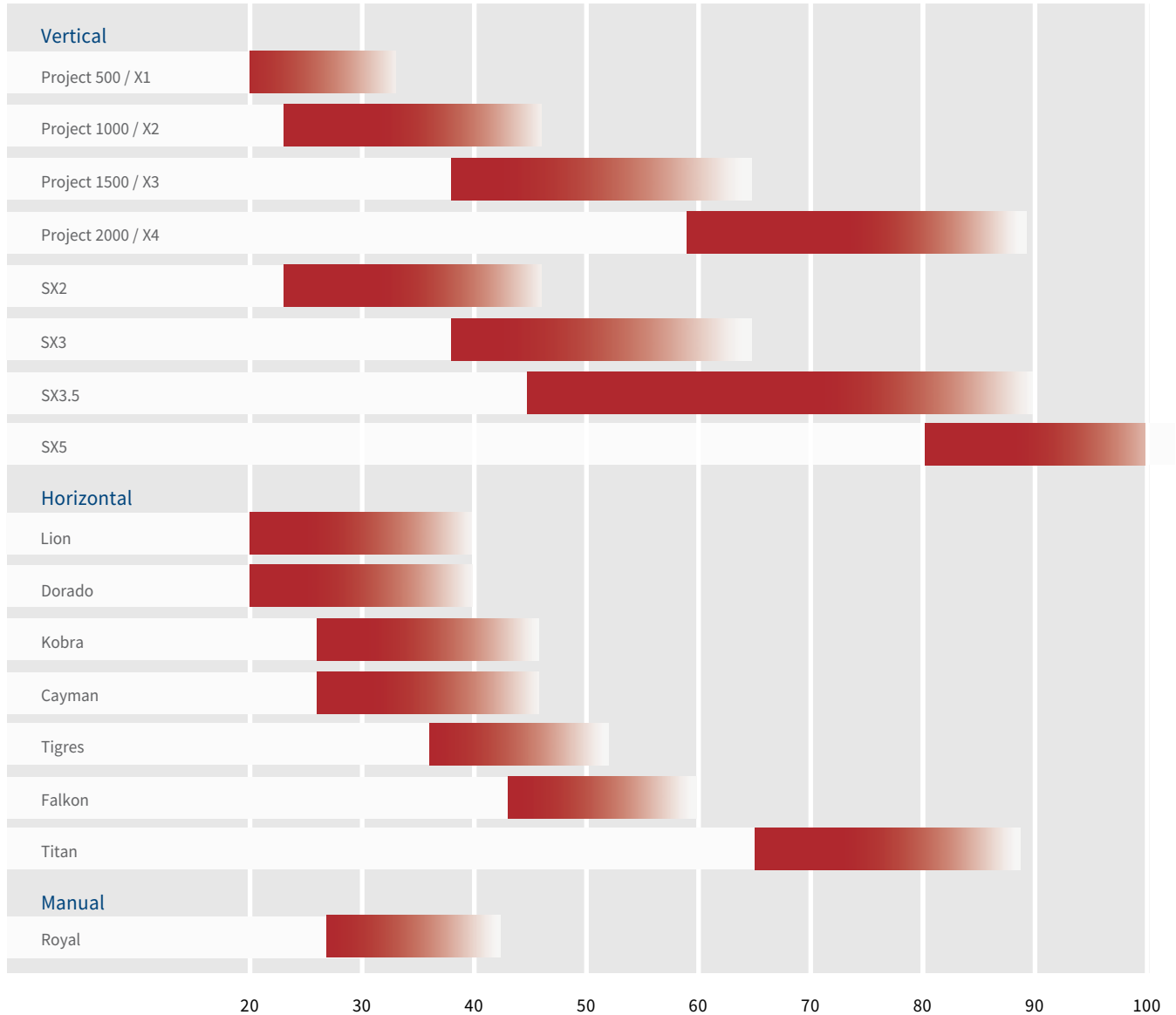
Lofrans vertical models offer contemporary styling and the latest features. Keyless mainshafts handle any unforeseen shockloads, unlike traditional keyway design.



Vertical or horizontal, electric or manual – Lofrans has it!

**LOFRANS WINDLASS SELECTION GUIDE**

Lofrans manufactures recreational windlasses to fit vessels from 20'-105' in length. Use this chart as a basic guide to help determine which type and model is best for you.



LOFRANS WINDLASSES

PLEASE NOTE: Recommendations for model selection by yacht length are intended for guidance purposes only; actual selection should be made after consulting with competent engineers.

**A network of support.**

Imtra's highly-trained regional representatives allow us to maintain close contact with individuals and marine tradespeople, and our knowledgeable in-house service department provides timely repairs and specialized windlass services to our customers (call for details). We are proud to back up our Lofrans product selection with technical expertise, online services, extensive product and parts availability as well as full warranty service throughout the USA.



LOFRANS WINDLASSES

VERTICAL

Project 500 / X1

Vertical rope/chain windlass for boats under 33'.

The Project 500/X1 can handle setting a lunch hook or an all chain rode in a heavy squall with power to spare. Offered with 500w or 800w motor.

Standard Equipment

- Two footswitches
- Watertight control box
- Clutch release handle
- Neoprene mounting gasket
- Deck stud clearance allowance 1"

Features

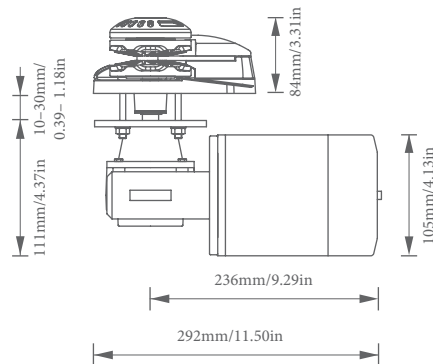
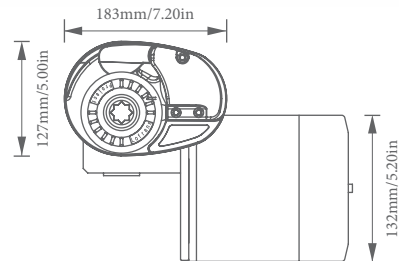
Finish	Chrome
Motor	(500W): Dual Direction, Permanent Magnet (800W): Dual Direction, Permanent Magnet
Gearbox	Stainless Worm Drive Radially Adjustable
Gears	Bronze
Mainshaft	Stainless
Chainpipe	Fixed
Chain Stripper	Stainless
Mounting Hardware	SS Studs, Washers and Nuts
Manual Override	N/A
Rope Capstan	Optional
Additional Deck Studs	1 3/4"
Extra Long Shaft/Deck Studs	4 3/4"

Specifications

Power Supply	12V	12V
Motor Wattage	500W	800W
Power Rating (lbs.)	970	1075
Approx. Amp Draw	30-60	50-110
Max Retrieval Speed (ft./min.)	69	85
Chain Size/Type	1/4" (HT)	
Rope Size	1/2"	
Net Weight (lbs.)	25	29
Maintenance Kit	LWP72037	



Photo: Sea Ray, Inc.



Vertical electric windlasses in low profile or capstan versions.

**VERTICAL**

**Project 1000 / X2**

Vertical rope/chain windlass for boats from 23'-46'.

The Project 1000/X2 is a robust, powerful rope/chain windlass capable of managing all chain rodes for bluewater cruisers and coastal cruisers alike.

**Standard Equipment**

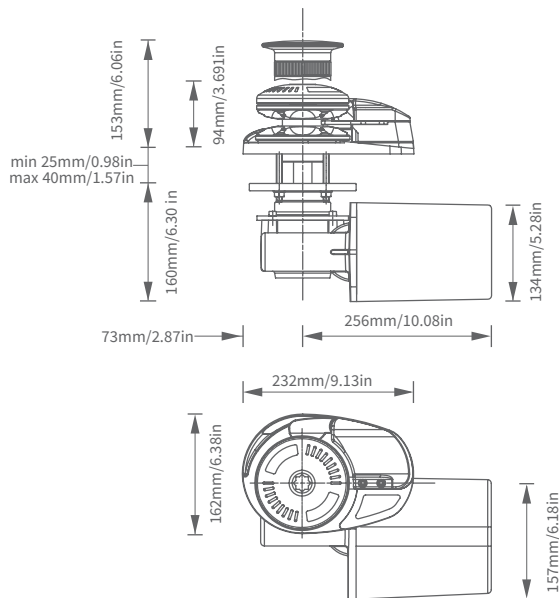
- Two footswitches
- Watertight control box
- Clutch/manual operation handle
- Neoprene mounting gasket
- Deck stud clearance allowance 13/4"

**Features**

Finish	Chrome
Motor	Dual Direction, Series Wound
Gearbox	Stainless Worm Drive Radially Adjustable
Gears	Bronze
Mainshaft	Stainless
Chainpipe	Fixed
Chain Stripper	Stainless
Mounting Hardware	SS Studs, Washers and Nuts
Manual Override	Standard
Rope Capstan	Optional
Additional Deck Studs	23/4"
Extra Long Shaft/Deck Studs	5"

**Specifications**

Power Supply	12V	24V
Motor Wattage	1000W	1000W
Power Rating (lbs.)	1500	1500
Approx. Amp Draw	70-120	40-60
Max Retrieval Speed (ft./min.)	75	75
Chain Size/Type	5/16" (HT)	
Rope Size	9/16", 5/8"	
Net Weight (lbs.)	45	45
Maintenance Kit	LWP72038	



**Low Profile or Capstan?**

**factoid**

All Lofrans vertical windlasses are offered with and without a rope capstan. Low profile versions keep the foredeck uncluttered and visually pleasing. Capstan versions have a rope drum that operates independently of the rope/chain gypsy, an advantage when using two anchors or as a snubbing winch in docking maneuvers.

LOFRANS WINDLASSES

LOFRANS WINDLASSES

VERTICAL

Project 1500 / X3

Vertical rope/chain windlass for boats from 39'-65'.

The Project 1500/X3 is available with a variety of motor and gypsy combinations and low profile models feature Lofrans' lockable clutch system.

Standard Equipment

- Two footswitches
- Watertight control box
- Clutch/manual operation handle
- Neoprene mounting gasket
- Deck stud clearance allowance 23/4"

Features

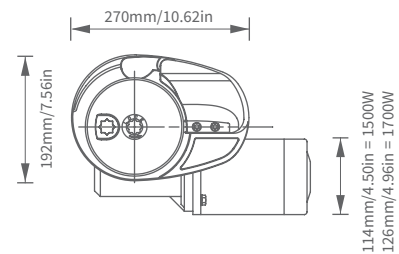
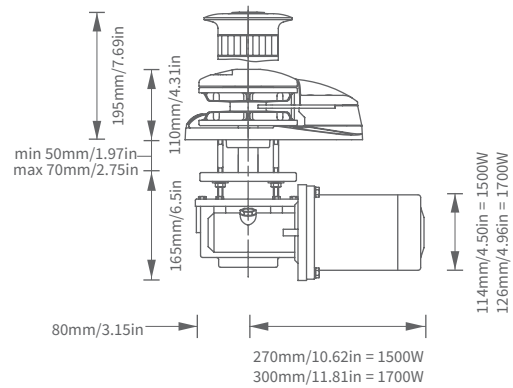
Finish	Chrome
Motor	Dual Direction, Series Wound
Gearbox	Stainless Worm Drive Radially Adjustable
Gears	Bronze
Mainshaft	Stainless
Chainpipe	Fixed
Chain Stripper	Stainless
Mounting Hardware	SS Studs, Washers and Nuts
Manual Override	Standard
Rope Capstan	Optional
Extra Deck Clearance	Optional (to 5")
Additional Deck Studs	3 1/2"

Specifications

Power Supply	12V or 24V	12V or 24V
Motor Wattage	1500W	1700W
Power Rating (lbs.)	1850	2450
Approx. Amp Draw	80-130 (12V) 50-70 (24V)	95-135 (12V) 50-70 (24V)
Max Retrieval Speed (ft./min.)	60	60
Chain Size/Type	5/16", 3/8" (HT)	
Rope Size	5/8", 3/4"	
Net Weight (lbs.)	77	84
Maintenance Kit	LWP72040	



Photo: Hylas Yachts



factoid Lofrans Maintenance Kits

Every Lofrans windlass has a corresponding maintenance kit that includes the most common replacement parts in an all-inclusive package.



Vertical electric windlasses in low profile or capstan versions.

VERTICAL

**Project 2000 / X4**

Vertical all chain windlass for boats from 59'-90'.

The Project 2000/X4 is ideal for larger, bluewater yachts both new and classic. The gypsy manages all chain rodes. Capstan version handles 9/16" - 3/4" rope on the drum.

**Standard Equipment**

- Two footswitches
- Watertight control box
- Clutch/manual operation handle
- Brake band
- Deck stud clearance allowance 5 1/4"

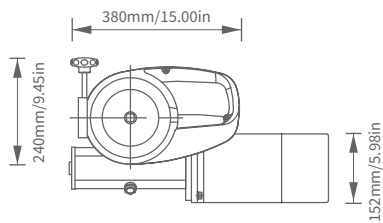
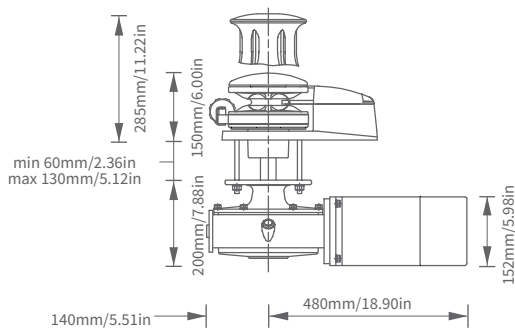
**Features**

Finish	Chrome
Motor	Dual Direction, Series Wound
Gearbox	Stainless Worm Drive Radially Adjustable
Gears	Bronze
Mainshaft	Stainless
Chainpipe	Fixed
Chain Stripper	Stainless
Mounting Hardware	SS Studs, Washers and Nuts
Manual Override	Standard
Rope Capstan	Optional

**Specifications**

*Power Supply	24V	24V
Motor Wattage	2300W	2700W
Power Rating (lbs.)	3075	3675
Approx. Amp Draw	100-190	110-200
Max Retrieval Speed (ft./min.)	78	78
Chain Size/Type	5/16", 7/16"(HT), 3/8", 1/2" (HT, BBB)	
Rope Size	9/16"- 3/4" (Capstan only)	
Net Weight (lbs.)	159	159

\*For details on AC or hydraulic units, please contact Imtra at 508-995-7000.



LOFRANS WINDLASSES

VERTICAL

SX2 and SX3

Vertical all chain windlass for boats 22'-45' (SX2) and 38'-65' (SX3).

SX2 and SX3 are round base, chain only with optional stand-alone chainpipe.

Standard Equipment

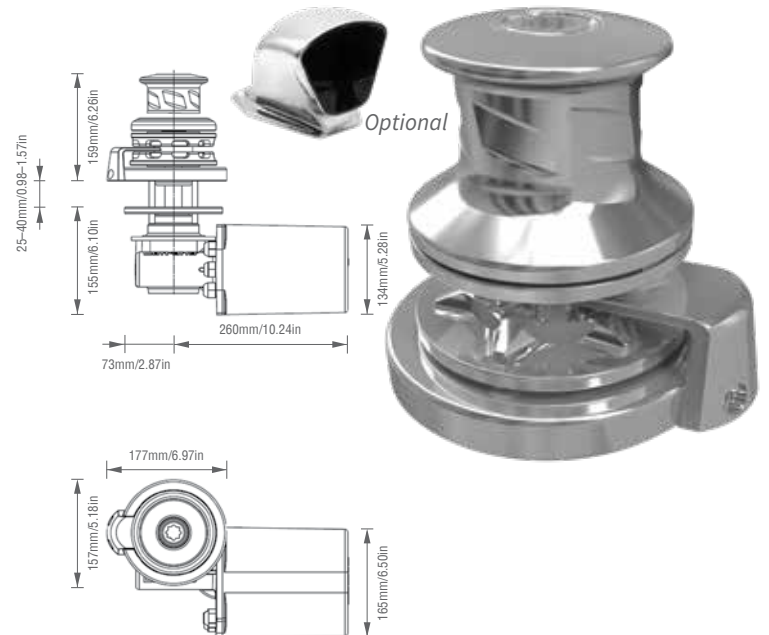
- Two footswitches
- Watertight control box
- Clutch handle
- Neoprene mounting gasket
- Deck stud clearance allowance 23/4"

Features

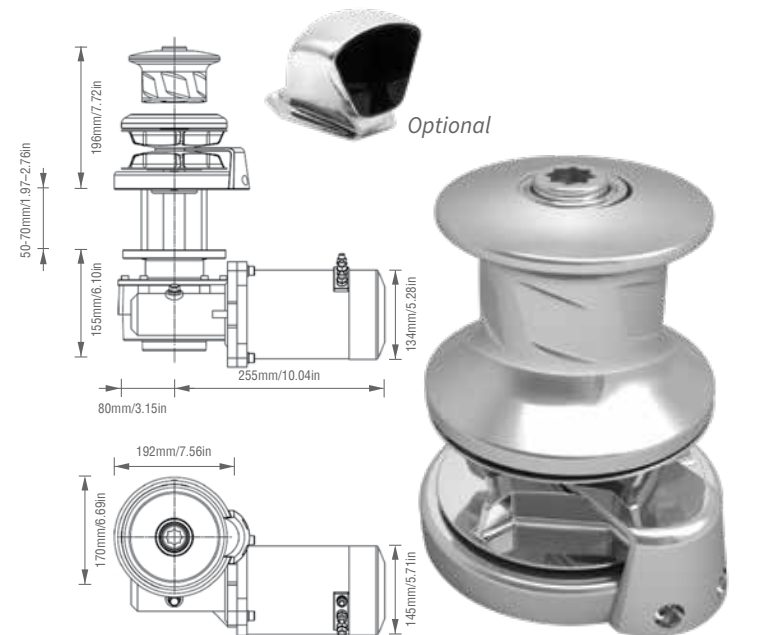
Finish	316 Stainless Steel		
Motor	12V/1000W, 12V/1500, 24V/1500W, 12V/1700W, 24V/1700W		
Gearbox	90 degree reduction drive		
Gears	Bronze		
Mainshaft	Stainless		
Chainpipe	Independent + optional		
Chain Stripper	Stainless		
Mounting Hardware	Stainless steel studs, washers & nuts		
Manual Override	No		
Rope Capstan	Optional		
Extra Deck Clearance	Optional (to 5")		

Specifications

	SX2	SX3	SX3
Power Supply	12V	12V or 24V	12V or 24V
Motor Wattage	1000	1500	1700
Power Rating (lbs.)	1500	1850	2450
Approx. Amp Draw	70/120(12V)	80-130 (12V) 50-70 (24V)	95-135 (12V) 50-70 (24V)
Max Retrieval Speed	70	60	60
Chain Size/Type	5/16", 3/8" (HT)		
Net Weight (lbs.)	44	77	84



Low-profile model available



Vertical electric windlasses in low profile or capstan versions.

**VERTICAL**

**SX3.5 and SX5**

Vertical all chain windlass for boats from 45'-90' (SX3.5) and 80'-100' (SX5).

The SX3.5 and SX5 are round base, chain only, with optional stand-alone chainpipe and a fitted wheel brake.

**SX3.5 Standard Equipment**

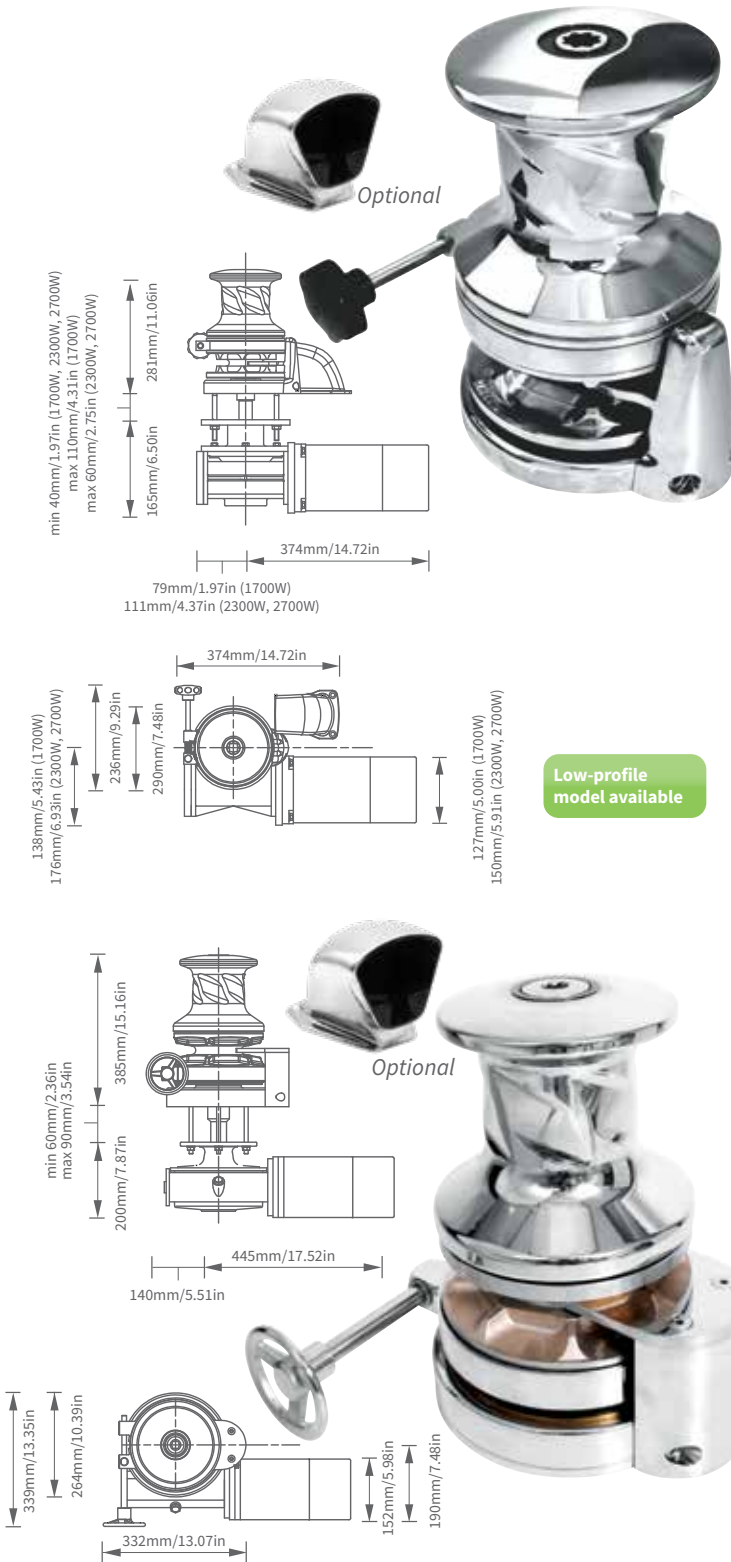
- Capstan drum
- Wheel brake
- Chainpipe
- Deck fasteners
- Clutch handle
- Solenoid control box
- Two footswitches
- Deck stud clearance allowance 23/4"

**Features**

Finish	316 Stainless Steel		
Motor	SX3.5 (12V/1700W, 24V/1700W, 24V/2300W) SX5(24V/3000W)		
Gearbox	90 degree reduction drive		
Gears	Bronze		
Mainshaft	Stainless		
Chainpipe	Independent + optional		
Chain Stripper	Stainless		
Mounting Hardware	10mm x 5" studs included		
Manual Override	No		
Rope Capstan	Yes		
Extra Deck Clearance	Optional		

**Specifications**

	SX3.5	SX3.5	SX5
Power Supply	12V or 24V	24V	24V
Motor Wattage	1700W	2300W	3000W
Power Rating (lbs.)	2600	3075	4300
Approx. Amp Draw	135 (12V) 70 (24V)	110 (24V)	260 (24V)
Max Retrieval Speed	105 (ft./min.)	105 (ft./min.)	95 (ft./min.)
Chain Size/Type	3/8" (HT), 1/2" (HT)		
Net Weight (lbs.)	110	110	220



LOFRANS WINDLASSES

HORIZONTAL

Lion 1000

Horizontal rope/chain windlass for boats up to 40'.

The Lofrans Lion horizontal windlass is a compact windlass featuring a 700W motor for boats up to 40 feet. *An automatic free fall option is available.*

Standard Equipment

- Watertight control box
- Clutch release handle
- Neoprene mounting gasket

Features

Finish	White Painted Aluminum Body
Motor	700W
Gearbox	Stainless Worm Drive
Gears	Bronze
Mainshaft	Stainless
Chainpipe	Built-in
Chain Stripper	Stainless Steel
Mounting Hardware	Stainless Steel Studs, washer and nuts
Manual Override	N/A
Rope Capstan	N/A
Extra Deck Clearance	N/A

Specifications

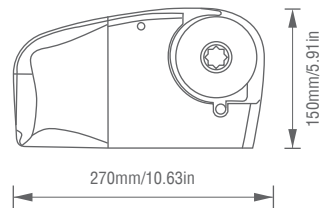
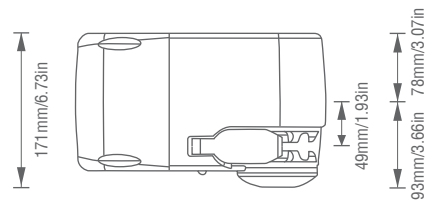
Power Supply	12V
Motor Wattage	700W
Power Rating (lbs.)	875
Approx. Amp Draw	60
Max Retrieval Speed (ft./min.)	85
Chain Size/Type	1/4" - 5/16 (HT)
Rope Size	1/2"
Net Weight (lbs.)	25



Photo: Striper Boats

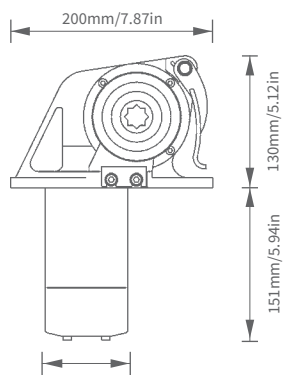


Optional: Automatic Free-Fall

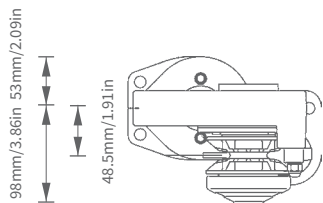




Horizontal electric-windlass (with drop-in motor) for boats from 20' to 46'.



500W:82mm/3.23in; 700W:94mm/3.70in



**HORIZONTAL**

**Dorado**

Horizontal rope/chain windlass for boats up to 40'.

Dorado's vertically-mounted motor and small profile are ideal for boats with restricted anchor lockers. Offered with 500W or 800W motor.

**Standard Equipment**

- Watertight control box
- Clutch release handle
- Neoprene mounting gasket

**Features**

Finish	Anodized
Motor	(500W): Dual Direction, Permanent Magnet (800W): Dual Direction, Permanent Magnet
Gearbox	Stainless Worm Drive
Gears	Bronze
Mainshaft	Stainless
Chainpipe	Deck Ring
Chain Stripper	Aluminum
Mounting Hardware	Insulated Bushings Only
Manual Override	N/A
Rope Capstan	N/A
Extra Deck Clearance	N/A

**Specifications**

Power Supply	12V	12V
Motor Wattage	500W	800W
Power Rating (lbs.)	970	1075
Approx. Amp Draw	30-60	50-110
Max Retrieval Speed (ft./min.)	69	85
Chain Size/Type	1/4" (HT)	
Rope Size	1/2"	
Net Weight (lbs.)	22	24
Maintenance Kit	LWP72047	

**Drop-In Installation**



Drop-in installations are quick, simple, and ideal for small or restricted anchor lockers. The motor installs vertically directly under the windlass housing to save space. The assembled windlass is mounted by passing the motor through the deck hole. Only stud tightening and wire connections are done from under the deck.

LOFRANS WINDLASSES

HORIZONTAL

Kobra

Horizontal windlass for boats from 26'-46'.

Kobra's vertically-aligned motor and compact above-deck profile make it ideal for crowded foredecks and installations where space is limited.

Standard Equipment

- Two footswitches
- Watertight control box
- Clutch/manual operation handle

Features

Finish	Anodized
Motor	Dual Direction, Permanent Magnet
Gearbox	Stainless Worm Drive
Gears	Bronze
Mainshaft	Stainless
Chainpipe	Deck Ring
Chain Stripper	Stainless
Mounting Hardware	Insulated Bushings Only
Manual Override	Standard
Rope Capstan	Standard
Extra Deck Clearance	N/A

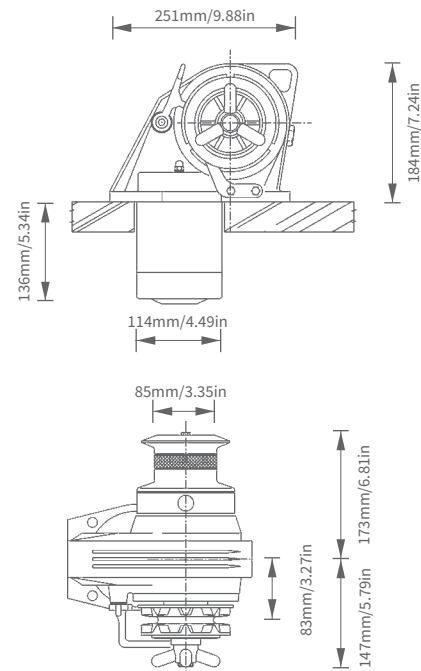
Specifications

Power Supply	12V	24V
Motor Wattage	1000W	1000W
Power Rating (lbs.)	1900	2000
Approx. Amp Draw	70-120	40-60
Max Retrieval Speed (ft./min.)	75	75
Chain Size/Type	1/4" (HT), 5/16", 3/8" (HT, BBB, PC)	
Rope Size	1/2" - 3/4" (Rope Drum)	
Net Weight (lbs.)	46	46
Maintenance Kit	LWP72048	

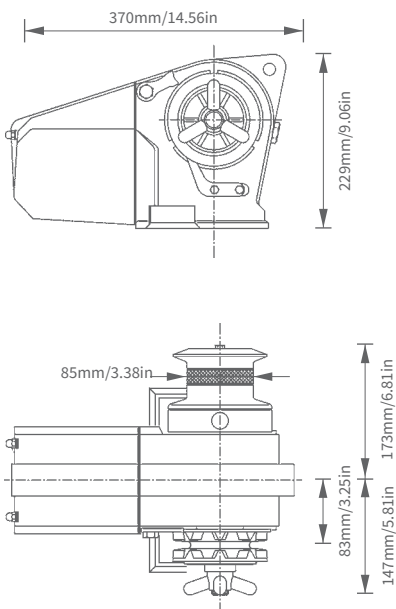


Photo: Nordic Tugs

Coming Soon: Rope/Chain Management Upgrade Kits



Coming Soon: Rope/Chain Management Upgrade Kits



**HORIZONTAL**

**Cayman**

Horizontal windlass for boats from 26'-46'.

Sturdy, sleek and compact, Cayman features a 1000W motor, standard manual-override, all-chain retrieval and separate rope capstan. Mounting studs thread discreetly into the housing.

**Standard Equipment**

- Two footswitches
- Watertight control box
- Clutch/manual operation handle
- Rubber mounting gasket

**Features**

Finish	Anodized
Motor	Dual Direction, Series Wound
Gearbox	Stainless Worm Drive
Gears	Bronze
Mainshaft	Stainless
Chainpipe	Rubber Ring
Chain Stripper	Stainless
Mounting Hardware	SS Studs, Washers and Nuts
Manual Override	Standard
Rope Capstan	Standard
Extra Deck Clearance	N/A

**Specifications**

Power Supply	12V
Motor Wattage	1000W
Power Rating (lbs.)	1900
Approx. Amp Draw	70-120
Max Retrieval Speed (ft./min.)	65
Chain Size/Type	1/4" (HT), 5/16", 3/8" (HT, BBB, PC)
Rope Size	1/2" - 3/4" (Rope Drum)
Net Weight (lbs.)	44
Maintenance Kit	LWP72048

LOFRANS WINDLASSES

HORIZONTAL

Tigres

Horizontal windlass for boats from 36'-52'.

One of the all-time most popular windlasses, Tigres' unique features include a handy top-mounted snubbing cleat, standard manual-overdrive, all-chain retrieval, and oil-level window. Charter companies select Tigres for its durable, trouble-free design.

Standard Equipment

- Two footswitches
- Watertight control box
- Clutch/manual operation handle

Features

Finish	Anodized
Motor	Dual Direction, Series Wound
Gearbox	Stainless Worm Drive
Gears	Bronze
Mainshaft	Stainless
Chainpipe	Deck Ring
Chain Stripper	Stainless
Mounting Hardware	Insulated Bushings Only
Manual Override	Standard
Rope Capstan	Standard
Extra Deck Clearance	N/A

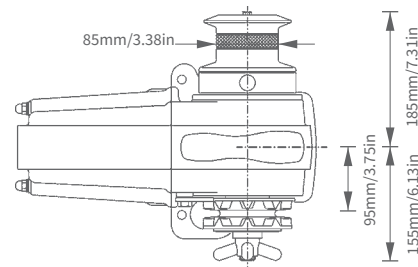
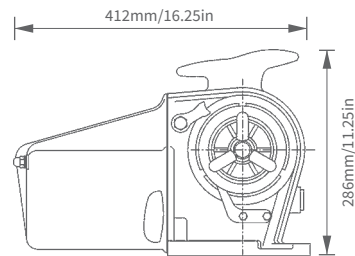
Specifications

Power Supply	12V	24V
Motor Wattage	1500W	1500W
Power Rating (lbs.)	2300	2400
Approx. Amp Draw	80-130	50-70
Max Retrieval Speed (ft./min.)	80	80
Chain Size/Type	1/4" (HT), 5/16", 3/8" (HT, BBB, PC)	
Rope Size	1/2" - 3/4" (Rope Drum)	
Net Weight (lbs.)	61	61
Maintenance Kit	LWP72050	



Photo: American Tugs

Coming Soon: Rope/Chain Management Upgrade Kits



Lofrans Maintenance Kits

factoid

Every Lofrans windlass has a corresponding maintenance kit that includes the most common replacement parts in an all-inclusive package.



Horizontal electric-windlasses for boats from 36' to 60'.

**HORIZONTAL**

**Falcon**

Horizontal windlass for boats from 43'-60'.

Falcon is ideal for large cruising vessels that anchor frequently with heavy offshore, all-chain ground-tackle. Once the rode is in place, back up your chainstopper with the included brake band. Contact Imtra for details on special versions, including dual gypsies, or custom configurations.

**Standard Equipment**

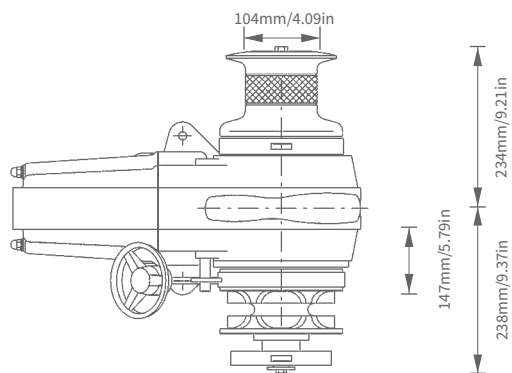
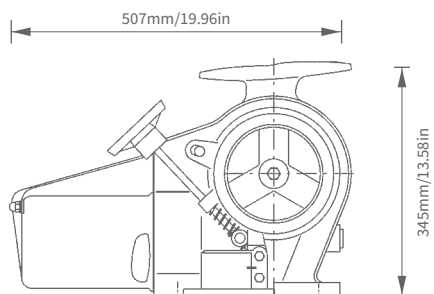
- Two footswitches
- Watertight control box
- Clutch/manual operation handle
- Chainpipe

**Features**

Finish	Anodized
Motor	Dual Direction, Series Wound
Gearbox	Stainless Worm Drive
Gears	Bronze
Mainshaft	Stainless
Chainpipe	Stand-Alone w/Adj. Stripper
Chain Stripper	Stainless
Mounting Hardware	Insulated Bushings Only
Manual Override	Standard
Rope Capstan	Standard
Extra Deck Clearance	N/A

**Specifications**

Power Supply	12V	24V
Motor Wattage	1700W	1700W
Power Rating (lbs.)	2600	2700
Approx. Amp Draw	90-135	50-70
Max Retrieval Speed (ft./min.)	60	60
Chain Size/Type	5/16", 7/16" (HT), 3/8", 1/2" (HT, BBB)	
Rope Size	1/2" - 3/4" (Rope Drum)	
Net Weight (lbs.)	103	103
Maintenance Kit	LWP72051	



LOFRANS WINDLASSES

LOFRANS WINDLASSES

HORIZONTAL



Photo: Nordhavn Yachts

Titan

Horizontal heavy-lift windlass for boats from 65'-89'.

Titan is designed for big boat tackle, and is available in a variety of configurations. The popular "B" model (shown) includes gypsies to starboard and port for ground-tackle retrieval, and a convenient top-mounted rope drum. Contact Imtra for custom configurations.

Standard Equipment

- Two footswitches
- Watertight control box
- Clutch/manual operation handle
- Chainpipe(s)

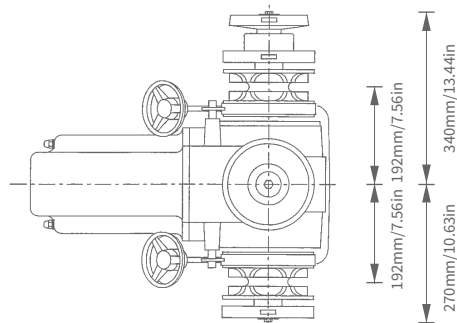
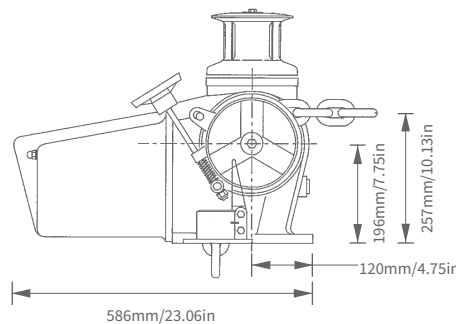
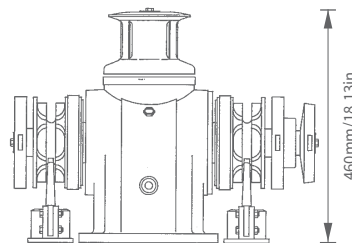
Features

Finish	Anodized
Motor	DC: Dual Direction, Series Wound AC: Various Motor Options Available
Gearbox	Stainless Worm Drive
Gears	Bronze
Mainshaft	Stainless
Chainpipe	Stand-Alone w/ Adj. Stripper
Chain Stripper	Stainless
Mounting Hardware	Insulated Bushings Only
Manual Override	Standard
Rope Capstan	Standard
Extra Deck Clearance	N/A

Specifications

Power Supply	24V
Motor Wattage	2300W
Power Rating (lbs.)	4100
Approx. Amp Draw	100-190
Max Retrieval Speed (ft./min.)	50
Chain Size/Type	7/16" (HT), 3/8", 1/2" (HT, BBB)
Rope Size	1/2" - 3/4" (Rope Drum)
Net Weight (lbs.)	200-250

For details on AC or hydraulic units, please contact Imtra at 508-995-7000.



Manual electric-windlasses for boats from 26' to 89'.

**HORIZONTAL**

**Royal**

Manual rope/chain windlass for boats from 26'-42'.

For some smaller vessels without sufficient electrical systems, a manual windlass makes sense. Royal is easy to install and features a smooth, double-action operation that makes anchoring a quick and simple task.

**Standard Equipment**

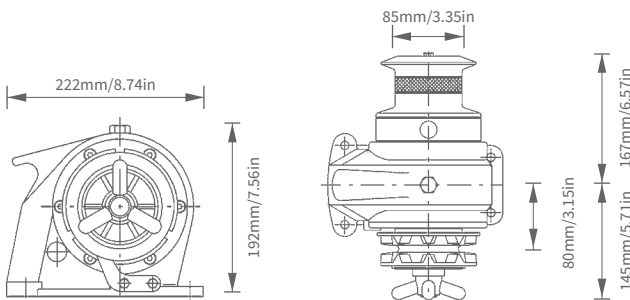
Manual operation handle

**Features**

Finish	Anodized
Motor	N/A
Gearbox	Bevel Gears
Gears	Aluminum
Gear Ratio	1.2:1
Mainshaft	Stainless
Chainpipe	Not Included
Chain Stripper	Stainless
Mounting Hardware	Insulated Bushings Only
Rope Capstan	Standard
Extra Deck Clearance	N/A

**Specifications**

Power Rating (lbs.)	440
Chain Size/Type	1/4" (HT), 5/16", 3/8" (HT, BBB, PC)
Rope Size	1/2" - 3/4" (Rope Drum)
Net Weight (lbs.)	22
Maintenance Kit	LWP72046



**NEW**  
Stainless Steel Series  
Available, please inquire.

**When a Manual is the Right Choice.**



In many circumstances, a manual windlass makes the most sense. Electrical limitations, infrequent anchoring and often budget considerations, make this choice a significant upgrade from the back-breaking, hand-over-hand method of recovering ground tackle.

**CAPSTANS**

**Vertical Capstans**

Typically installed on the stern to aid in docking and mooring situations. Lofrans vertical capstans feature high quality 316 stainless warping drums and anodized aluminum gearboxes.

MUIR WINDLASSES



Muir – a dominant force for innovative anchoring technology and dependability.

Since 1968, Muir has been recognized as an industry leader in anchoring systems worldwide. Muir windlasses and anchoring systems rest on the deck of many of the world's largest and most respected production-built vessels.



A Muir anchoring system is an investment in security and peace of mind. Utilizing the most advanced technologies, Muir technicians and engineers have developed systems to suit the luxury mega yacht, pleasure craft and commercial vessel market.

In recognition of this expertise, Muir has received numerous industry awards,

including Tasmania's Exporter of the Year.



Photo: Viking Yachts

Muir innovation and integrity.

Muir have not only perfected the rope/chain combination windlass but developed the Rope/Chain Management System for smooth rope to chain. They have advanced the windlass ratchet system for controlled manual override, and integrated complete units with swivel chain pipes onto a single base.

Muir Storm vertical windlasses are available with two different clutch systems. Models with MOS (Manual Operating System) have a fixed-cone clutch. For manual anchor recovery, remove the capstan (on SSC models) or top cap (SS units) and insert a special handle (ordered separately) into the top of the gypsy.



Manual Operating System (MOS)



Manual OverRide System (MORS)

Models with MORS (Manual OverRide System) feature a ratchet pawl assembly within the cone clutch. These units can be configured in two ways: electric dual direction (for power up and down) or electric retrieval with manual override. When in the latter configuration, manual recovery of the anchor is accomplished by inserting a standard winch handle (one is included with each windlass) directly into the top of the capstan or clutch cap.

If the unit is configured for dual-direction electrical operation, manual retrieval is still possible after re-positioning the ratchet pawls, located underneath the cone clutch. Most users configure windlasses with MORS for dual-direction knowing they can easily reconfigure the unit if manual operation becomes necessary.

Quality, not compromise.

Muir systems are manufactured with only the finest-quality, marine-grade materials and components. Heavy duty electric motors are series-wound for greater power, faster retrieval and increased dependability. Smaller windlasses incorporate permanent magnet motors. All models feature stainless steel shafts, bronze gears and cone clutches, along with chrome-plated bronze chain gypsies.

Striving to maintain the highest quality standards, Muir is accredited with ISO 9001 certification. With their superior performance and durability, Muir products have become popular with high-speed ferries, military craft, workboats, as well as high quality yacht builders.

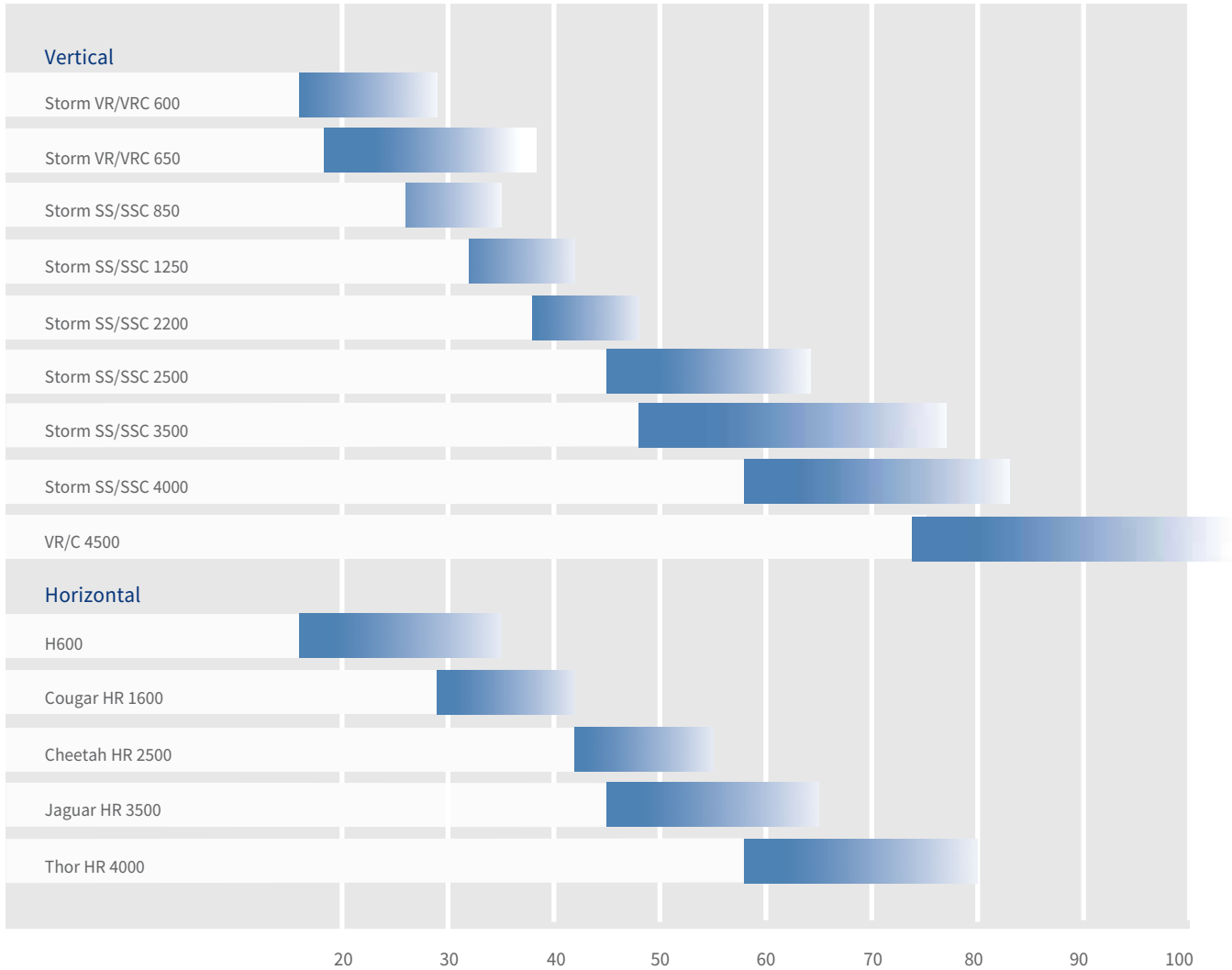
Polished bronze finish is available for select models, inquire.



Vertical and horizontal models from a leader in anchor technology and innovation.

**MUIR WINDLASS SELECTION GUIDE**

Muir manufactures a range of windlasses to fit vessels from 16'-105' in length. Use this chart as a basic guide to help determine which type and model is best for you.



MUIR WINDLASSES

PLEASE NOTE: Recommendations for model selection by yacht length are intended for guidance purposes only; actual selection should be made after consulting with competent engineers. Please refer to page 33 for Muir Heavy Lift.

**A network of support.**

Imtra's highly-trained regional representatives allow us to maintain close contact with individuals and marine tradespeople, and our knowledgeable in-house service department provides timely repairs and specialized windlass services to our customers (call for details). We are proud to back up our Muir product selection with technical expertise, online services, extensive product and parts availability as well as full warranty service throughout North America.



MUIR WINDLASSES

VERTICAL

Storm 600

Vertical rope/chain windlass for boats from 16'-29'.

The 600's radially-adjustable lower unit allows the motor to be positioned in virtually any position, making it easy to fit in small anchor lockers.

Standard Equipment

- Footswitch
- Watertight control box
- Clutch release handle
- Max 60mm deck clearance
- Quickfit Coupler



Features

Finish	Stainless Steel
Motor	Dual Direction, Permanent Magnet
Gearbox	Stainless Worm Drive, Self-Aligning Radially Adjustable
Gears	Bronze
Mainshaft	Stainless
Chainpipe	Fixed
Chain Stripper	Chrome with Stainless Steel Band
Mounting Hardware	SS Studs, Washers and Nuts
Manual Override	N/A
Rope Capstan	Optional
Extra Deck Clearance	Optional Studs (to 6")
QuickFit Adapter	Stainless Steel

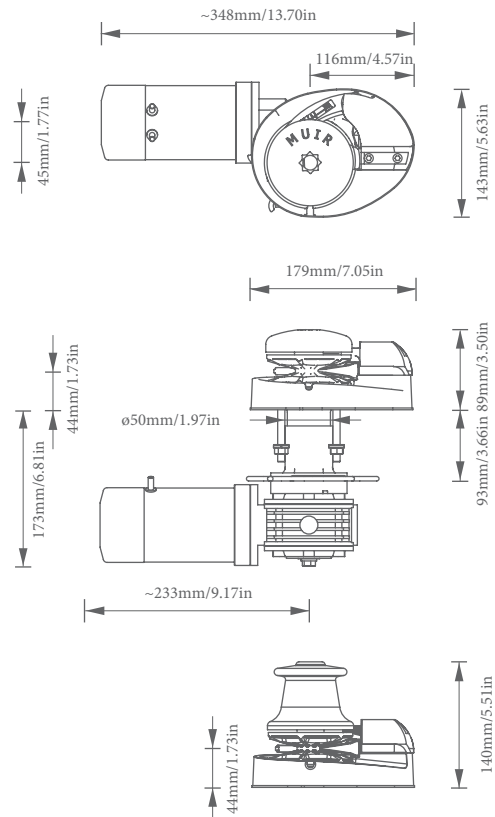
Specifications

Power Supply	12V
Motor Wattage	600W
Power Rating (lbs.)	500
Approx. Amp Draw	80
Max Retrieval Speed (ft/min.)	80
Chain Size/Type	1/4" (HT)
Rope Size	1/2"
Net Weight (lbs.)	28



SSC 600

SS 600



Vertical electric windlasses in low profile and capstan versions.

VERTICAL

Storm 650

Vertical manual windlass for boats from 19'-38'.

Not everyone needs or wants power, so this Manual Vertical windlass is designed with those people in mind. There are many applications and the above deck installation is fast and simple.

Standard Equipment

- Stainless steel mounting bolts
- Operator's Handle
- Rope/Chain combo gypsy

Features

Finish	Stainless Steel
Motor	Manual
Mainshaft	Stainless
Chainpipe	Swiveling
Chain Stripper	Stainless Steel with Stainless Steel Band
Mounting Hardware	SS Studs, Washers and Nuts
Rope Capstan	Optional

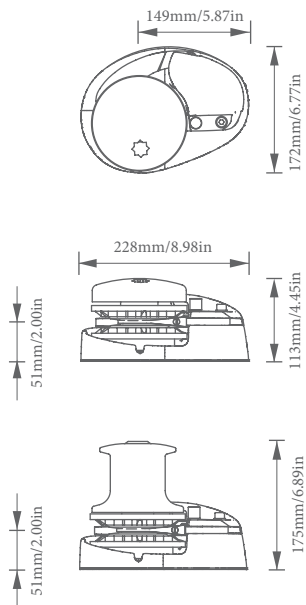
Specifications

Vessel Length (ft.)	19-38
Power Supply	Manual
Max Load (lbs.)	500
Recovery Rate	14.5" / revolution
Chain Size	5/16" - 3/8" (HT, BBB)
Net Weight (lbs.)	20



SSC 650

SS 650



MUIR WINDLASSES

VERTICAL

Storm 850

Vertical rope/chain windlass for boats from 26'-35'.

The 850's rope/chain management system swallows rodes with ease. Muir's 360° chain stripper and aft-facing pressure finger guide the rode down the chainpipe to ensure trouble-free transitions from chain to rope.

Standard Equipment

- Footswitch
- Clutch release handle
- Max 60mm deck clearance
- Quickfit Coupler



Features

Finish	Stainless Steel
Motor	Dual Direction, Permanent Magnet
Gearbox	Stainless Worm Drive, Self-Aligning Radially Adjustable
Gears	Bronze
Mainshaft	Stainless
Chainpipe	Swiveling
Chain Stripper	Stainless Steel with SS Band
Mounting Hardware	SS Studs, Washers and Nuts
Manual Override (MOS)	Optional Handle Required
Rope Capstan	Optional
Extra Deck Clearance	Optional Studs (to 6")
QuickFit Adapter	Stainless Steel

Specifications

Power Supply	12V
Motor Wattage	600W
Power Rating (lbs.)	600
Approx. Amp Draw	80
Max Retrieval Speed (ft./min.)	80
Chain Size/Type	5/16", 3/8" (HT, BBB)
Rope Size	1/2", 9/16", 5/8"
Net Weight (lbs.)	37



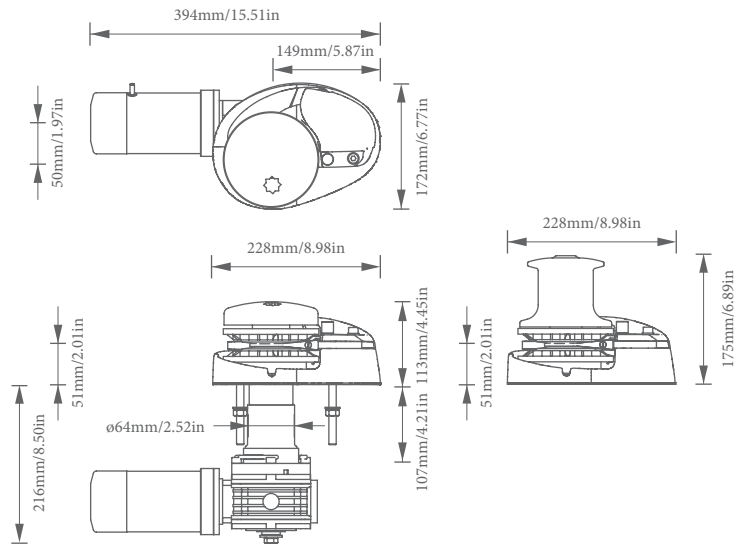
Photo: Bayliss Yachts



SSC 850



SS 850



factoid Self-Aligning QuickFit Gearbox Coupler

This feature allows the gearbox and motor to be installed directly onto the shaft in any radial position and alleviates installation problems due to uneven deck thickness. This is helpful when installing a windlass onto a deck with any camber to the deck surface. QuickFit connection simplifies installation. Look for this icon.



Vertical electric windlasses in low profile and capstan versions.

VERTICAL

Storm 1250

Vertical rope/chain windlass for boats from 32'-42'.

Muir's 1250 features a 1000W motor for powerful retrieval and a host of nice touches like its clever swiveling chainpipe, a radially-adjustable gearbox, and mirror-like stainless steel finish.

Standard Equipment

- Footswitch
- Clutch release handle
- Max 60mm deck clearance
- Quickfit Coupler



Features

Finish	Stainless Steel
Motor	Dual Direction, Series Wound
Gearbox	Stainless Worm Drive, Self-Aligning Radially Adjustable
Gears	Bronze
Mainshaft	Stainless
Chainpipe	Swiveling
Chain Stripper	Stainless Steel with SS Band
Mounting Hardware	SS Studs, Washers and Nuts
Manual Override (MOS)	Optional Handle Required
Rope Capstan	Optional
Extra Deck Clearance	Optional Studs (to 6")
QuickFit Adapter	Stainless Steel

Specifications

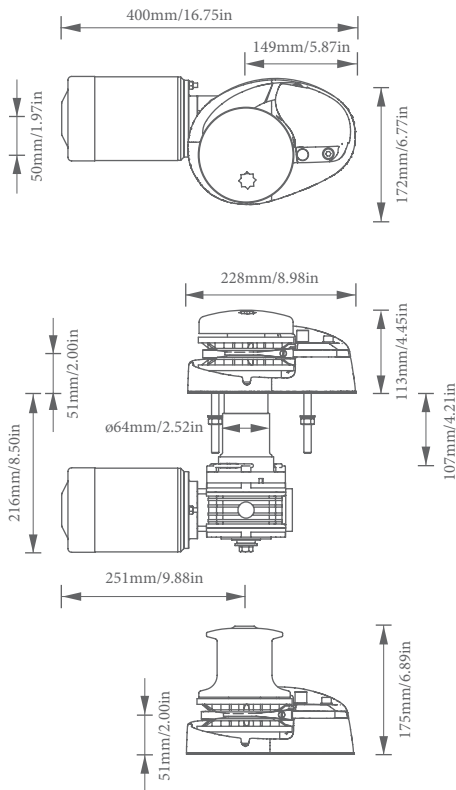
Power Supply	12V	24V
Motor Wattage	1000W	1000W
Power Rating (lbs.)	1100	1100
Approx. Amp Draw	100	60
Max Retrieval Speed (ft./min.)	48	48
Chain Size/Type	5/16", 3/8" (HT, BBB)	
Rope Size	1/2", 9/16", 5/8"	
Net Weight (lbs.)	44	48

MUIR WINDLASSES



SSC 1250

SS 1250



Muir Pressure Finger

factoid

Muir vertical windlasses through the 4000 series feature a robust and handsome stainless steel pressure finger with adjustable tension easily set by the operator.



MUIR WINDLASSES

VERTICAL

Storm 2200

Vertical rope/chain windlass for boats from 38'-48'.

The 2200 features identical topworks to the 1250 (and 850) yet this powerhouse has the "63" gearbox and 1200W motor of its bigger brother, the Storm 2500.

Standard Equipment

- Footswitch
- Clutch release handle
- Max 60mm deck clearance



Features

Finish	Stainless Steel or Bronze
Motor	Dual Direction, Series Wound
Gearbox	Stainless Worm Drive, Self-Aligning Radially Adjustable
Gears	Bronze
Mainshaft	Stainless
Chainpipe	Swiveling
Chain Stripper	Stainless Steel with SS Band
Mounting Hardware	SS Studs, Washers and Nuts
Manual Override (MOS)	Optional Handle Required
Rope Capstan	Optional
Extra Deck Clearance	Optional Studs (to 6")
QuickFit Adapter	Stainless Steel

Specifications

Power Supply	12V	24V
Motor Wattage	1200W	1200W
Power Rating (lbs.)	2200	2200
Approx. Amp Draw	120	75
Max Retrieval Speed (ft./min.)	50	50
Chain Size/Type	5/16", 3/8" (HT, BBB)	
Rope Size	1/2", 9/16", 5/8"	
Net Weight (lbs.)	52	55



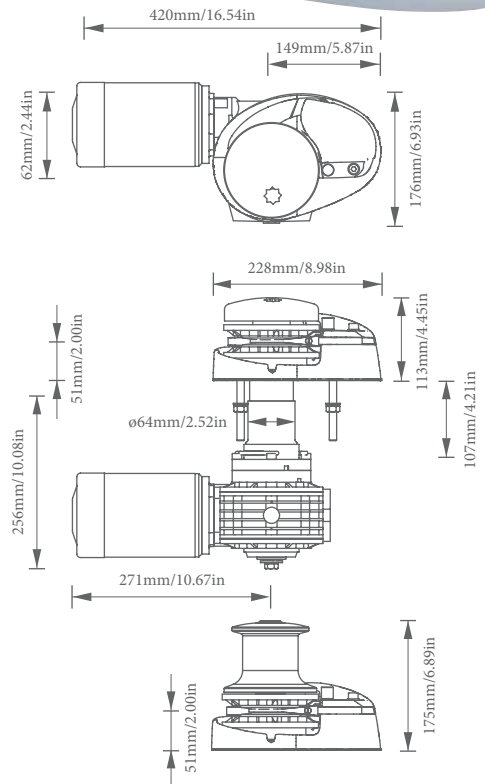
Photo: Fleming Yachts



SSC 2200



SS 2200



**Bronze Finish Available - Special Order - Inquire**

Vertical electric windlasses for larger yachts.

VERTICAL

Storm 2500/3500

Vertical rope/chain windlass for boats from 45'-77'.

The 2500 and 3500 windlasses share the same topworks and "63" gearbox. The 2500 is driven by a 1200W motor; the 3500 by a 1500W motor. Both units accept rope/chain combination or all chain rodes.

Standard Equipment

- Footswitch
- Clutch release handle
- Max 60mm deck clearance

Features

Finish	Stainless Steel
Motor	Dual Direction, Series Wound
Gearbox	Stainless Worm Drive, Self-Aligning Radially Adjustable
Gears	Bronze
Mainshaft	Stainless
Chainpipe	Swiveling
Chain Stripper	Chrome with Stainless Steel Band
Mounting Hardware	SS Studs, Washers and Nuts
Manual Override (MORS)	Optional
Rope Capstan	Optional
Extra Deck Clearance	Optional Studs (to 6")

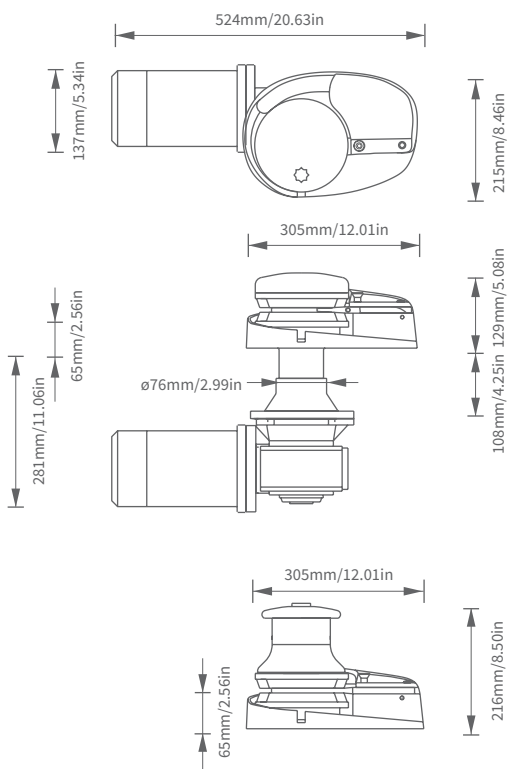
Specifications

Power Supply	12V or 24V	12V or 24V
Motor Wattage	1200W	1500W
Power Rating (lbs.)	2500	3500
Approx. Amp Draw	120 (12V) 75 (24V)	150 (12V) 85 (24V)
Max Retrieval Speed (ft./min.)	44	44
Chain Size/Type	5/16", 7/16" (HT), 3/8", 1/2" (HT, BBB)	
Rope Size	9/16", 5/8", 3/4"	
Net Weight (lbs.)	92	101



SSC 2500/3500

SS 2500/3500



MUIR WINDLASSES

VERTICAL

Storm 4000

Vertical rope/chain windlass for boats from 58'-83'.

The 4000 is driven by a 2000W motor to lift even the heaviest loads. The rope drum on SSC models is taller to accept the larger anchor and docking lines of large yachts. Hydraulic versions are also available.

Standard Equipment

- Footswitch
- Clutch release handle
- Max 60mm deck clearance

Features

Finish	Stainless Steel
Motor	Dual Direction, Series Wound
Gearbox	Stainless Worm Drive, Self-Aligning Radially Adjustable
Gears	Bronze
Mainshaft	Stainless
Chainpipe	Swiveling
Chain Stripper	Chrome with Stainless Steel Band
Mounting Hardware	SS Studs, Washers and Nuts
Manual Override (MORS)	Optional
Rope Capstan	Optional
Extra Deck Clearance	Optional Studs (to 6")

Specifications

Power Supply	24V or Hydraulic
Motor Wattage	2000W
Power Rating (lbs.)	4000A
Approx. Amp Draw	70
Max Retrieval Speed (ft./min.)	44
Chain Size/Type	7/16" (HT), 3/8", 1/2" (HT, BBB)
Rope Size	9/16", 5/8", 3/4"
Max Hydraulic Flow	5.8 gal/min
Max Hydraulic Pressure	2900PSI
Net Weight (lbs.)	119

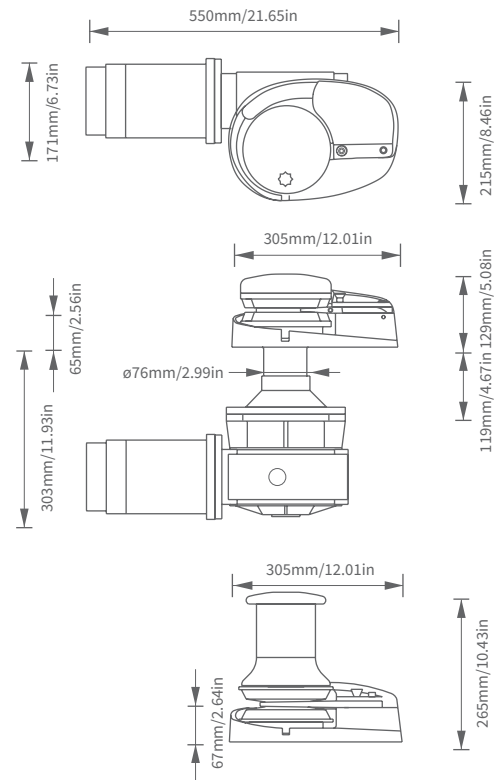


Photo: Fleming Yachts



SS 4000

SSC 4000



Mirror Image Windlasses

Muir offers mirror image versions of its 2500, 3500 and 4000 verticals. For large yachts fitting a pair of vertical windlasses, the primary drive systems are reversed on the left-hand model so rodes rotate in opposite directions (clockwise on starboard unit; counter-clockwise on port windlasses).

factoid



Vertical electric windlasses for larger yachts.

VERTICAL

VR/C 4500

Vertical rope/chain windlass for boats from 75'-105'.

Vertical Windlass (CCW) Rotation, AC/DC or hydro motor coupled to HD right-angle drive gearbox, chain gypsy to suit, Polished 316 Stainless Capstan, Cone Drive System, 431 Stainless Shaft and SS Lined Brake Band.

Standard Equipment

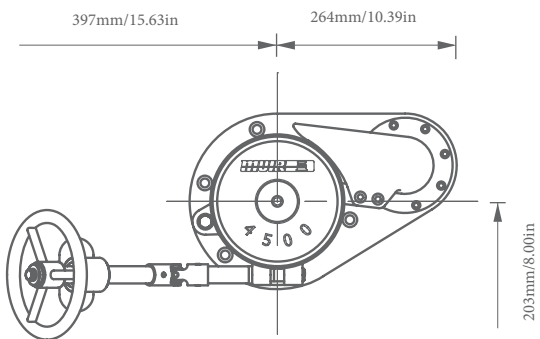
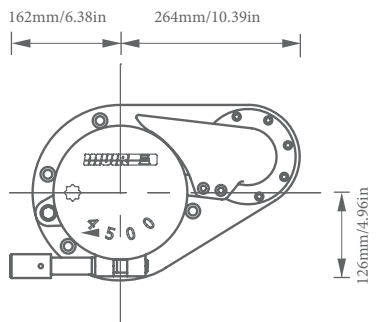
- Chanipipe
- Straight brake nut
- Clutch handle
- Brake handle
- Deck studs: length 100mm from bottom of base to end of stud & hardware
- Counterbalance valve fitted (hydro only)

Features

Finish	Polished 316 S/Steel
Motor	24VDC, Hyd, 3ph AC
Gearbox	STM 110
Gears	Bronze
Mainshaft	431 Stainless Steel
Chainpipe	Polished 316
Chain Stripper	Polished 316
Mounting Hardware	Deck Studs Supplied
Manual Override	Optional on AC Version
Rope Capstan	Standard on VRC4500
Extra Deck Clearance	Optional

Specifications

Power Supply	24V, Hydraulic or AC
Motor Wattage	24VDC 2500/3500W - 4KW AC Drive
Power Rating (lbs.)	4500
Approx. Amp Draw	105A (24v/2500w) or 145A (24v/3500w)
Max Retrieval Speed (ft./min.)	66
Chain Size/Type	1/2", 5/8" (HT/SL), 12.5/14mm U2 Stud
Rope Size	N/A
Max Hydraulic Flow	13.8 gal/min
Max Hydraulic Pressure	2900PSI
Net Weight (lbs.)	275



Mega Yacht windlasses & mooring equipment

If it's Mega, it's Muir.

Muir is the brand of choice for today's mega yachts. They offer a range of anchoring and mooring systems for vessels up to 150 meters and pull strengths exceeding 15,000kg. Muir is globally recognized as the leader



Photo: Muir

in anchoring systems for larger luxury motor and sailing yachts. Muir's success in the luxury yacht market is driven by a strong

commitment to product development and innovation. By working closely with naval architects, designers, builders, captains, engineers and owners, they have maintained their position at the forefront of the yachting industry.

Muir offers high power-to-weight-ratio equipment combined with highly efficient planetary drive gears. Their medium to high pressure hydraulics and one, two or variable speed AC electric drives will achieve the ideal anchoring system to suit nearly any vessel. In addition, Muir surpasses the most stringent classification requirements, providing the confidence demanded by cruising and charter operators around the world. Muir anchoring systems can be found, in a variety of finishes, on the foredeck of today's most elegant sail, motor or expedition yachts.

Manufactured in Australia, Muir equipment is distributed in over 60 countries and backed by the highest level of customer support. Customers across the globe can rely on a Muir anchoring and docking system for long term durability and dependability.

Make Muir your choice when selecting your yacht's ground tackle management system.



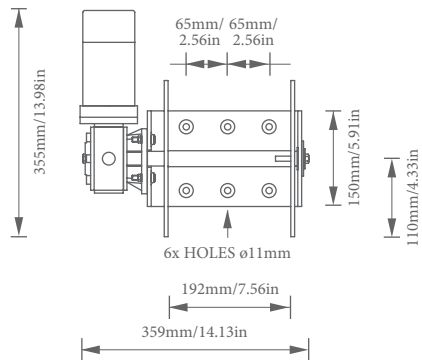
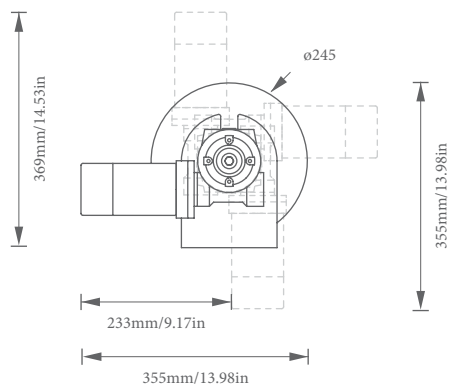
**Service and Support**

factoid

Please contact Imtra Headquarters regarding service and replacement parts. Visit our website at [www.imtra.com/anchoring-windlasses-heavy-lift-muir.htm](http://www.imtra.com/anchoring-windlasses-heavy-lift-muir.htm) to fill out a short questionnaire which will help us make a recommendation.

Compact anchoring system to suit boats with little or no anchor rode storage.

VERTICAL



DW08/DW10/DW12/DW15

Drum Winches for boats from 16' - 47'.

Anchoring made easy, fast and reliable with a Muir Drum Winch. Choose either the standard Power Up & Power Down or Auto Free Fall Models.

Standard Equipment

- Circuit Breaker
- Reversing Solenoid Pack
- Helm Control Switch and Fascia Panel
- Simple tools & hardware

Features

- Compact Anchoring system to suit boats with little or no anchor rode storage
- Simple installation
- "Tangle free" rope and chain operation
- Larger Drum capacity

Specifications

Model	DW08/ DFF08	DW10/ DFF10	DW12 DFF12	DW15/ DFF15
Vessel Length (ft)	16-26	26-34	34-40	40-47
Power Supply (DC)	12V	12/24V	12/24V	12/24V
Motor Wattage	600	1000	1200	1500
Max Load (lbs.)	400	575	690	860
Max Line Speed (m/min)	33	33	33	33
Chain Size	1/4"	5/16"	5/16"	3/8"
Rope Size	5/16"	3/8"	3/8"	1/2"
Net Weight (lbs.)	33/35	66/68	70/75	77/82



4" (MF841161) and 8" (MF841178) version rollers available

MUIR WINDLASSES

HORIZONTAL

Cougar

Horizontal chain, rope or rope/chain windlass for boats from 29'-42'.

Ratcheting manual recovery, beautiful white FRP, bushed mounting points, and optional rope/chain management system are a few of the best features of this popular windlass.

Standard Equipment

- Footswitch
- Clutch/manual operation handle
- Chainpipe

Features

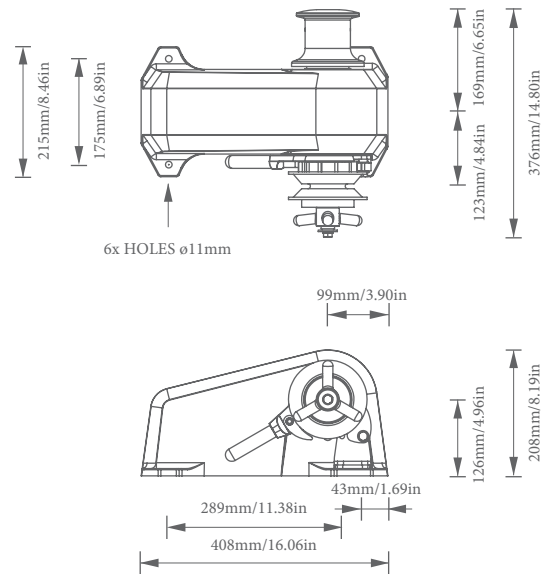
Finish	FRP (Fiberglass Reinforced Plastic)
Motor	Dual Direction, Series Wound
Gearbox	Stainless Worm Drive
Gears	Bronze
Mainshaft	Stainless
Chainpipe	Optional
Chain Stripper	Stainless
Mounting Hardware	Insulated Bushings Only
Manual Override	Standard
Rope Capstan	Standard
Extra Deck Clearance	N/A

Specifications

Power Supply	12V	24V
Motor Wattage	1000W	1000W
Power Rating (lbs.)	1200	1200
Approx. Amp Draw	100	60
Max Retrieval Speed (ft./min.)	46	46
Chain Size/Type	5/16", 3/8" (HT, BBB)	
Rope Size	1/2", 9/16", 5/8"	
Net Weight (lbs.)	55	55

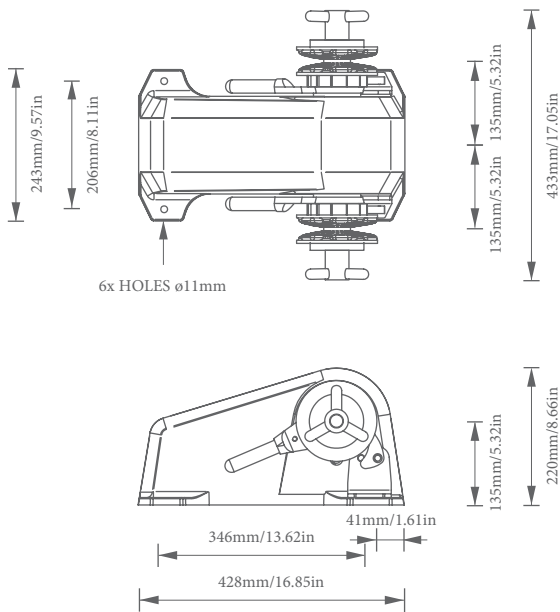


Photo: CW Hood 30



Horizontal electric windlasses for boats from 30' to 45'.

**HORIZONTAL**



**Cheetah**

Horizontal windlass for yachts from 38'-45'.

This rugged unit is fitted with a starboard chainwheel and port capstan as standard. Dual gypsy models are available upon request.

**Standard Equipment**

- Footswitch
- Chainpipe
- Clutch/manual operation handle
- Optional dual gypsy configuration

**Features**

Finish	FRP (Fiberglass Reinforced Plastic)
Motor	Dual Direction, Series Wound
Gearbox	Stainless Worm Drive
Gears	Bronze
Mainshaft	Stainless
Chainpipe	Standard
Chain Stripper	Standard with Chainpipe
Mounting Hardware	Insulated Bushings Only
Manual Override	Standard
Rope Capstan	Standard
Extra Deck Clearance	N/A

**Specifications**

Power Supply	12V	24V
Motor Wattage	1200W	1200W
Power Rating (lbs.)	2500	2500
Approx. Amp Draw	120	75
Max Retrieval Speed (ft./min.)	48	48
Chain Size/Type	5/16" (HT, BBB), 3/8" (HT, BBB), 7/16" (HT)	
Rope Size	9/16", 5/8", 3/4"	
Net Weight (lbs.)	79	79

MUIR WINDLASSES

**factoid** **Dual Gypsies**

Many bluewater yachts are configured to deploy two bow anchors. If both are to be primarily all chain systems, a windlass with dual gypsies makes the most sense. Each gypsy can be engaged (or disengaged) to allow individual operation of each chain rode. Imtra offers dual gypsy models from both Muir and Lofrans.

MUIR WINDLASSES

HORIZONTAL



Jaguar

Horizontal windlass for yachts from 45'-65'.

Jaguar features a 1500W motor for high-powered performance. Its size makes it a good choice for cruising boats with high-sided bulwarks and divided chain lockers.

Standard Equipment

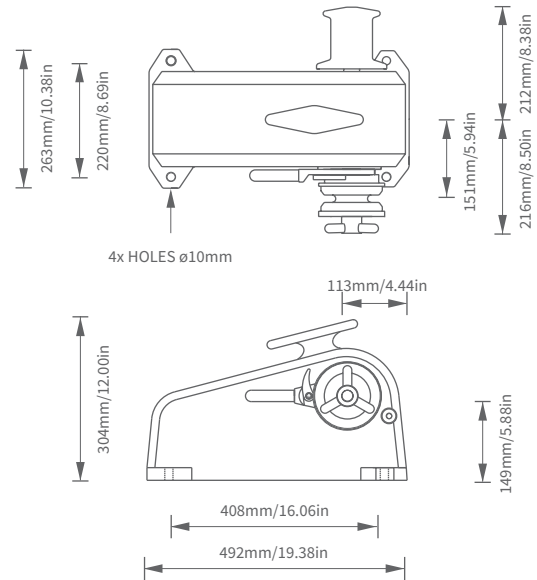
- Footswitch
- Chainpipe
- Clutch/manual operation handle
- Optional dual gypsy configuration

Features

Finish	White
Motor	Dual Direction, Series Wound
Gearbox	Stainless Worm Drive
Gears	Bronze
Mainshaft	Stainless
Chainpipe	Standard
Chain Stripper	Standard with Chainpipe
Mounting Hardware	Insulated Bushings Only
Manual Override	Standard
Rope Capstan	Standard
Extra Deck Clearance	N/A

Specifications

Power Supply	12V	24V
Motor Wattage	1500W	1500W
Power Rating (lbs.)	3500	3500
Approx. Amp Draw	150	85
Max Retrieval Speed (ft./min.)	48	48
Chain Size/Type	5/16", 7/16" (HT), 3/8", 1/2" (HT, BBB)	
Rope Size	9/16", 5/8", 3/4"	
Net Weight (lbs.)	128	128



Horizontal electric windlasses for boats from 45' to 80'.

**HORIZONTAL**

**Thor**

Horizontal windlass for yachts from 58'-80'.

Available with DC electric or hydraulic motors that will easily retrieve chain up to 1/2" with speed. Thor is especially well-suited for heavy-displacement cruising yachts.

**Standard Equipment**

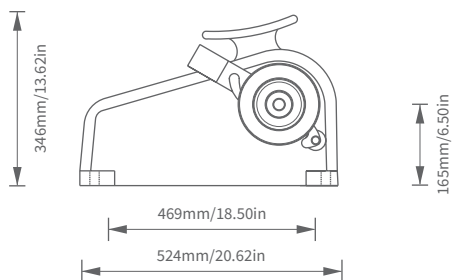
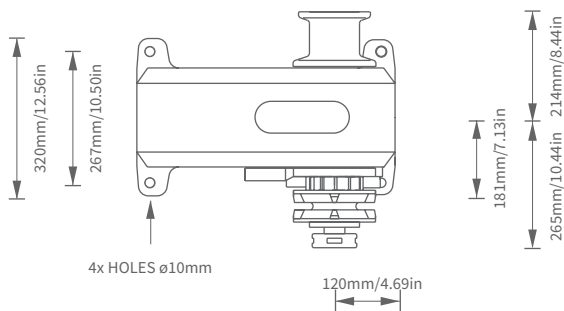
- Footswitch
- Chainpipe
- Clutch/manual operation handle
- Optional dual gypsy configuration

**Features**

Finish	White
Motor	Dual Direction, Series Wound
Gearbox	Stainless Worm Drive
Gears	Bronze
Mainshaft	Stainless
Chainpipe	Standard
Chain Stripper	Standard with Chainpipe
Mounting Hardware	Insulated Bushings Only
Manual Override	Standard
Rope Capstan	Standard
Extra Deck Clearance	N/A

**Specifications**

Power Supply	12V or 24V	24V
Motor Wattage	1500W	2000W
Power Rating (lbs.)	4000	4500
Approx. Amp Draw	150 (12V) 85 (24V)	120
Max Retrieval Speed (ft./min.)	44	44
Chain Size/Type	7/16", 5/8" (HT), 3/8", 1/2" (HT, BBB)	
Rope Size	5/8", 3/4"	
Net Weight (lbs.)	140	140



MUIR WINDLASSES

**SWITCHGEAR**

**Switchgear from Imtra makes anchoring easier and safer.**

The right switchgear enhances any windlass installation and makes anchoring safer and easier. Imtra has the high quality switchgear you're



Photo: Sea Ray, Inc.

looking for, with proven designs made from the best materials. Our products include footswitches, handhelds, simple and intelligent control panels, breakers, and control boxes.

Best of all, these choices allow you to customize your installation to get the most out of your anchoring system.



Photo: Carver Yachts



**High-Amperage Footswitches**

These covered or uncovered footswitches handle full windlass loads without an external solenoid or control box. The uncovered version offers a stainless steel bezel. The covered model (available in white or black) is hinged to fold flat to the deck when in use; when not in use, the cover closes to prevent accidental operation.

- 200 Amp continuous rating (@12VDC)
- 600 Amp “make or break”
- 4”(100mm) diameter
- 8mm studs for wiring connections
- Supplied with fasteners
- Contact activated

- SPA-10500K Uncovered Footswitch, Stainless Steel Bezel
  - SPA-10502K Covered Footswitch, Black
  - SPA-10504K Covered Footswitch, White
  - MF801047 Covered Footswitch, 316 Stainless, Muir
- All footswitches can be used with any model windlass*

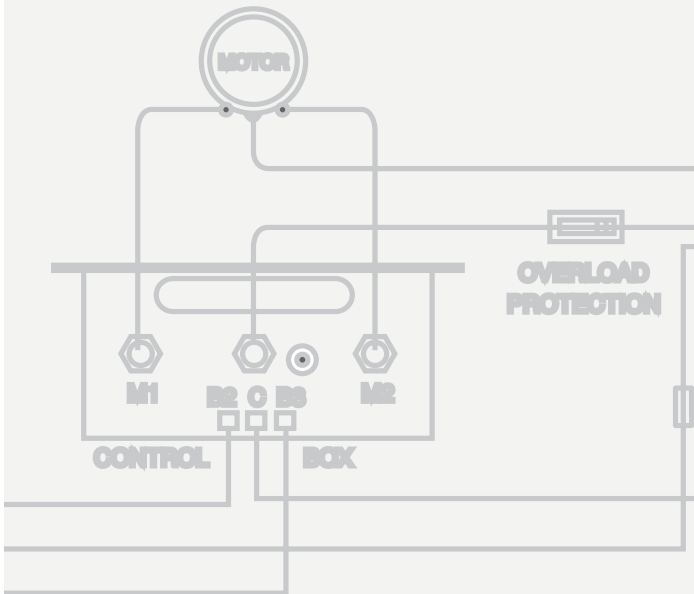


**Lofrans Low-Amperage Footswitches**

These covered, electronic footswitches need only a small 1/4" opening in the deck for wires to pass through, making them perfect for compact installations. Requires an external solenoid or control box.

- Hinged cover
- Choice of grey or white covers
- Boot up (black) or down (red)
- ‘Donut’ style cover allows fingertip operation
- Supplied with fasteners
- Contact activated

- LWP950G Low-Amp Footswitch  
Grey Cover, Black Boot (Up)
- LWP951G Low-Amp Footswitch  
Grey Cover, Red Boot (Down)
- LWP950W Low-Amp Footswitch  
White Cover, Black Boot (Up)
- LWP951W Low-Amp Footswitch  
White Cover, Red Boot (Down)





Footswitches, windlass control boxes, magnetic and thermal circuit breakers.



### Windlass Control Boxes

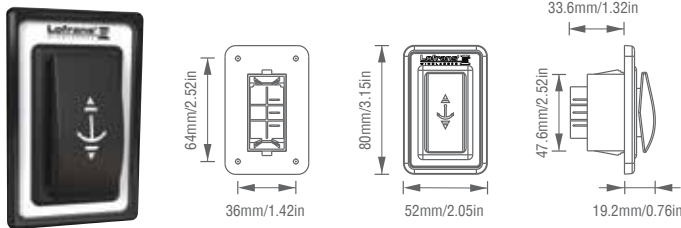
Watertight and pre-wired, our dual-solenoid control boxes are available for 2/4 or 3-wire windlass motors. Rated for continuous duty to 150 Amps (surge to 500 Amps).

Control Boxes for 3-Wire Motors

- SPA-20700 Watertight Control Box, 12V, 700 to 1700W
- SPA-20724 Watertight Control Box, 24V, 700 to 1700W
- SPA-20824 Watertight Control Box, 24V, 700 to 2300W

Control Boxes for 2- and 4-Wire Motors

- SPA-20697 Watertight Control Box, 12V, 500 to 1300W
- SPA-20696 Watertight Control Box, 24V, 500 to 1300W



### Rocker-Switch

Features a momentary rocker-switch certified to IP66 water resistance. These ignition-protected switches are vibration, moisture and salt-spray resistant.

- LWP610000C Lofrans Helm Control Rocker Switch



### Toggle Switch

Features a momentary switch for safe windlass operation. Rubber toggle cover ensures trouble-free performance in exposed locations. Size: 2" x 3 1/2"

- SPA-10550 Panel Mount Up/Down Remote Switch



### Thermal Breakers

We utilize popular Bussman® breakers for those desiring a thermal breaker. Available in 50, 70, 110 and 150A sizes, these breakers are offered in surface-mount or thru-bulkhead versions. Thru-Bulkhead models include a faceplate and install with a simple 2 1/8" holesaw cutout. Thru-Bulkhead models have an LED indicator light. All are IP66 for use in wet locations. Connections are 5/16" to accept large terminal lugs. All accept input voltage up to 48VDC.

- SPA-187050L 50 Amp, Thru-Bulkhead w/12V LED Indicator
- SPA-187070L 70 Amp, Thru-Bulkhead w/12V LED Indicator
- SPA-187110L 110 Amp, Thru-Bulkhead w/12V LED Indicator
- SPA-187150L 150 Amp, Thru-Bulkhead w/12V LED Indicator
- SPA-187LAMP24 24V LED Indicator Light only
- SPA-187050F 50 Amp, Surface Mount
- SPA-187070F 70 Amp, Surface Mount
- SPA-187110F 110 Amp, Surface Mount
- SPA-187150F 150 Amp, Surface Mount



### Helm Switch

Muir's Up/Down momentary rocker switch provides simple remote operation of all windlasses from the helm, flybridge or cockpit. Compact and contemporary in design and manufactured from marine grade materials, they manage both 12 & 24v current.

- MF801087 Up/Down Momentary Rocker Switch

SWITCHGEAR



Photo: Sabre Yachts



**AutoAnchor™ 560 Wired/Wireless Rode Counter and Windlass Controller**

This panel-mounted AutoAnchor offers stress-free anchoring at the touch of a button. The 560 is suitable for DC electric windlasses using all chain or rope/chain rode, as well as hydraulic or AC-powered windlasses using all-chain rode.

- Graphic LCD screen featuring intuitive user-interface for simple operation
- Adjustable backlit display in feet, meters or fathoms
- Preset stopping point on retrieval
- One-touch function to deploy and retrieve a preset length of rode
- Displays windlass speed and direction, plus battery voltage
- Safety lock to help protect against accidental windlass deployment
- Logs windlass operation hours to help ensure regular windlass maintenance
- Plug and play system
- Various sensor cables sold separately

SPA-AA560 AA560 Rode Counter and Windlass Control, Black  
 SPA-AA9110 Sensor Holder for Horizontal Windlasses (Sold Separately)

**AutoAnchor 150 Rode Counter**

This panel mount rode counter is designed for DC electric windlasses using an all-chain or rope/chain rode. Also suitable for hydraulic or AC-powered windlasses using all-chain rode. The large, adjustable LCD display lets you see exactly how much rode has been released (in feet or meters). Kit includes one console unit, one sensor and one magnet.

- Easy to install and set up
- Beeps to warn operator when the anchor is 4 feet from stowing
- Adjustable red backlighting for easy night-viewing
- Matches diameter of common marine-instrument gauges
- Supports multiple displays
- Plug and play system
- Various sensor cables sold separately

SPA-AA150 AutoAnchor 150 Rode Counter  
 SPA-AA9110 Sensor Holder for Horizontal Windlasses (Sold Separately)

**Sensor Cable for AA560 & AA150**

SPA-AA95xx Available in 5 different lengths, sold separately (required)



**AutoAnchor Handheld Remote Controls**

Handheld, wired remote controls from AutoAnchor. Each is supplied with marine plug, socket and cover, stowage bracket, and 7' spiral cord. Universal power supply (12 or 24VDC).

- A** 2-Function AutoAnchor Handheld Remote  
 SPA-AA9207 2-Function with 7' Spiral Cord
- B** 4-Function AutoAnchor Handheld Remote  
 SPA-AA9211 4-Function with 7' Spiral Cord
- C** 2-Function AutoAnchor Wired Handheld Remote with Chain Counter  
 SPA-AA9209 2-Function Wired Chain Counter (Complete Kit)

Remote controls and chain counters for windlasses.



**AutoAnchor 710 Handheld Wireless Remote**

Handheld, wireless remote control for windlasses using all chain or rope/chain rodes. This remote is shockproof and waterproof (it floats) with an LED backlit display. Complete kit includes hand remote, base station, magnet and sensor, holder and cover.

- Full Graphic LCD screen featuring intuitive user interface for simple operation
- Adjustable backlit display in feet, meters or fathoms
- Logs windlass operation hours to help ensure regular windlass maintenance
- Displays signal strength and battery level
- Ergonomic design with wrist strap
- 12 or 24VDC

SPA-AA9408	AA710 Complete Handheld Windlass Remote
SPA-AA9400	AA710 Handheld Remote only
SPA-AA9405	AA710 Base Station only
SPA-AA9403	AA710 Optional Antenna (often required on steel or carbon fiber boats)



**Quick™ Handheld Remote Controls**

Imtra offers the latest in handheld remote controls from Quick. Compact and watertight, these multi-purpose controls are manufactured using only the highest quality materials and components. Available in 2-, 4-, 6- or 8-function models, with or without an integrated LED lamp. Each is supplied with marine plug, socket and cover, stowage bracket, and 7' spiral cord. Universal power supply (12 or 24VDC).

- A** 2-Function Quick Handheld Remotes
 

SPA-HRC1002	2-Function with 7' Spiral Cord
SPA-HRC1002L	2-Function with 7' Spiral Cord & LED Lamp
- B** 4-Function Quick Handheld Remote
 

SPA-HRC1004	4-Function with 7' Spiral Cord
-------------	--------------------------------
- C** 6-Function Quick Handheld Remote
 

SPA-HRC1006	6-Function with 7' Spiral Cord
-------------	--------------------------------
- D** 8-Function Quick Handheld Remote
 

SPA-HRC1008	8-Function with 7' Spiral Cord
-------------	--------------------------------
- E** 2-Function Quick Handheld Remote w/Chain Counter
 

SPA-CHC1103M	2-Function with Chain Counter (Up/Down) & LED lamp
--------------	--

**Quick™ Wireless Handheld Remote Controls**

Multipurpose hand-held wireless radio controls for remote operation of on-board electric equipment such as cranes, gangways, windlasses, etc. Ability to control more receivers with one transmitter. Two functions can be activated at the same time. Controls can accept rechargeable batteries, float if dropped, and feature an LED backlit keyboard for easy viewing.

SPA-RRCP902	2-Button Pocket Type
SPA-RRCH902	2-Button Hand Held Type
SPA-RRCH904	4-Button Hand Held Type
SPA-RRCR902	2-Relay Receiver Box
SPA-RRCR904	4-Button Receiver Box
SPA-RRCANT81	External Antenna



SPA-RRCP902

SPA-RRCH902

SPA-RRCR902



## ANCHOR CHAIN & RODES



Imtra has the anchor chain, line and rodes that you need.

Imtra offers popular brands of anchor chain in three configurations: Grade 43 (G43) High-Tensile, BBB Grade 30 (3B), and Stainless Steel. G43 and stainless steel meet



ISO specifications. Anchor chain is available by the full drum, the half-drum or by the foot. Longer lengths may be special ordered upon or by request. To meet your individual specifications,

Imtra will create a customized rope/chain combination. We also stock the most popular combination rodes, shown on these pages.



### G43 High-Tensile Anchor Chain

ACCO® Grade 43 (G43) hot-galvanized, high-tensile has become an industry standard, combining high strength in a short-link chain that runs easily in anchor windlass gypsies. Available by the foot from 1/4"- 3/8"; in half-drums or in full drums from 1/4"- 5/8".

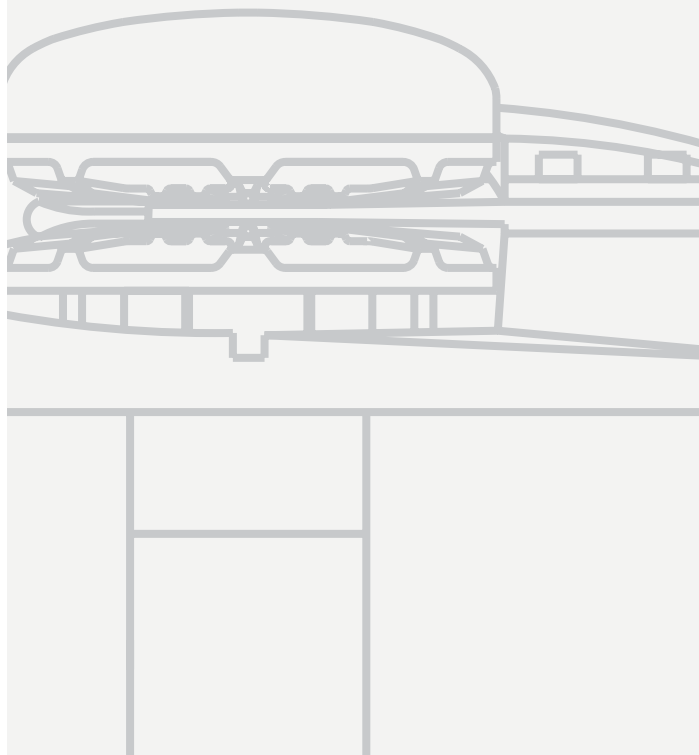


### Stainless Steel (SS)

Imtra's 316 stainless steel chain makes an attractive and functional alternative to galvanized chain, especially on rope/chain combination rodes. Available by the foot from 1/4"- 3/8"; in half drums or in full drums from 1/4"- 5/8".

### Oversize Links

Imtra can order full drum lengths of ACCO G43 chain (5/16"- 5/8") complete with oversize links on the end (s) to accept larger, stronger shackles. All are made to special order specifications. Contact Imtra for more information.



Anchor chain and custom or pre-made rodes to meet your requirements.

CHAIN SELECTION GUIDE

Use this chart as a basic guide to help determine which chain size and type is best for you.

	Item No. Per Foot	Item No. Half-Drum	Item No. Full-Drum	Chain Size	Working Load	Weight Per 100'	Full Drum Length	Drum Weight	Inside Dimensions	
									Length	Width
G43	AC40402	AC40402H	AC40402F	1/4"	2600 lbs.	74 lbs.	800'	586 lbs.	0.84"	0.41"
	AC40502	AC40502H	AC40502F	5/16"	3900 lbs.	104 lbs.	550'	570 lbs.	1.03"	0.50"
	AC40602	AC40602H	AC40602F	3/8"	5400 lbs.	149 lbs.	400'	595 lbs.	1.22"	0.60"
	AC40702	AC40702H	AC40702F	7/16"	7200 lbs.	215 lbs.	300'	645 lbs.	1.40"	0.66"
	AC40802	AC40802H	AC40802F	1/2"	9200 lbs.	254 lbs.	200'	507 lbs.	1.59"	0.77"
	AC41002	AC41002H	AC41002F	5/8"	13000 lbs.	388 lbs.	150'	582 lbs.	1.79"	0.90"
BBB	AC60502	AC60502H	AC60502F	5/16"	1950 lbs.	118 lbs.	550'	649 lbs.	1.00"	0.50"
	AC60602	AC60602H	AC60602F	3/8"	2750 lbs.	167 lbs.	400'	668 lbs.	1.09"	0.62"
	AC60802	AC60802H	AC60802F	1/2"	4750 lbs.	287 lbs.	200'	574 lbs.	1.34"	0.75"
	AC80402	AC80402H	AC80402F	1/4"	2930 lbs.	77 lbs.	800'	616 lbs.	0.84"	0.41"
SS	AC80502	AC80502H	AC80502F	5/16"	4250 lbs.	112 lbs.	550'	616 lbs.	1.03"	0.51"
	AC80602	AC80602H	AC80602F	3/8"	5860 lbs.	157 lbs.	400'	628 lbs.	1.22"	0.59"
	AC80802	AC80802H	AC80802F	1/2"	9465 lbs.	249 lbs.	200'	498 lbs.	1.59"	0.76"
	AC81002	AC81002H	AC81002F	5/8"	13400 lbs.	430 lbs.	150'	645 lbs.	1.79"	0.90"

Custom & Pre-Made Rodes

Imtra assembles custom anchor rodes to meet our customers' requirements. Working together with New England Ropes, we have created a proprietary anchor line that is durable, strong and works well in rope/chain anchor windlasses. With ropes from 1/2"-3/4" in diameter and ACCO chain from 1/4"-3/8" in size, we can make the perfect rode for your boat. In addition to our custom program, we stock the most popular combinations of rope and chain.

Pre-Made Rodes with 1/4" G43 Chain

- SPA-I1H8A R/C Rode, 8' x 1/4" HT Chain spliced to 150' x 1/2" Line
- SPA-I1H10A R/C Rode, 10' x 1/4" HT Chain spliced to 200' x 1/2" Line
- SPA-I1H15A R/C Rode, 15' x 1/4" HT Chain spliced to 200' x 1/2" Line
- SPA-I1H20C R/C Rode, 20' x 1/4" HT Chain spliced to 100' x 1/2" Line

Pre-Made Rodes with 5/16" G43 Chain

- SPA-I2H6A R/C Rode, 6' x 5/16" HT Chain spliced to 150' x 9/16" Line
- SPA-I2H15A R/C Rode, 15' x 5/16" HT Chain spliced to 200' x 9/16" Line
- SPA-I2H25A R/C Rode, 25' x 5/16" HT Chain spliced to 200' x 9/16" Line
- SPA-I2H25B R/C Rode, 25' x 5/16" HT Chain spliced to 200' x 5/8" Line
- SPA-I2H50B R/C Rode, 50' x 5/16" HT Chain spliced to 200' x 5/8" Line
- SPA-I2H30B R/C Rode, 30' x 5/16" HT Chain spliced to 200' x 9/16" Line

Pre-Made Rodes with 3/8" G43 Chain

- SPA-I3H30B R/C Rode, 30' x 3/8" HT Chain spliced to 200' x 3/4" Line
- SPA-I3H50D R/C Rode, 50' x 3/8" HT Chain spliced to 250' x 3/4" Line
- SPA-I3H25B R/C Rode, 25' x 3/8" SS Chain spliced to 200' x 5/8" Line

Pre-Made Rodes with Stainless Steel Chain

- SPA-I2S20A R/C Rode, 20' x 5/16" SS Chain spliced to 150' x 1/2" Line
- SPA-I3S25B R/C Rode, 25' x 3/8" HT Chain spliced to 200' x 5/8" Line
- SPA-I2S25B R/C Rode, 25' x 5/16" SS Chain spliced to 200' x 9/16" Line
- SPA-I2S250C R/C Rode, 20' x 3/8" SS Chain spliced to 250' x 5/8" Line
- SPA-I1S20B R/C Rode, 15' x 1/4" SS Chain spliced to 200' x 1/2" Line



ACCESSORIES

Put the finishing touches on your system with the right anchoring accessories.

Imtra has collected a variety of high quality products to complete your anchoring system. These items were selected specifically to work



Photo: Shutterstock

with Imtra's Lofrans and Muir windlass lines, yet will work equally well with most other anchoring systems. From chainstoppers to stainless steel anchor swivels, our full range of anchoring accessories will add to your boating safety, convenience and enjoyment.



Photo: The Hinckley Company



**Stainless Steel Chainstopper**

Our stainless steel chainstopper accommodates chain from 1/4" - 3/8", features a removal pawl (with lanyard) and safely works with loads of 5,000 lbs. The chainstopper mounts with two 3/8" fasteners (not included) and has a footprint that is 2 3/4" - 3 1/8".

SPA-6988S      Stainless Steel Chainstopper for 1/4"- 3/8"



**Polished Stainless Chainstoppers**

Imtra offers the Muir modular chainstopper system for larger applications. These stoppers are available in their base form but can be upgraded to include a Devil's Claw assembly with the optional conversion kits. Available in two sizes: 5/16" - 3/8" or 7/16" - 1/2". Larger sizes available by special order.

- MCLK316F10      Muir Chainstopper for 5/16" - 3/8" Chain
- MCLK316F13      Muir Chainstopper for 7/16" - 1/2" Chain
- MDCKIT10          Devil's Claw Conversion Kit for MCLK31610A
- MDCKIT13          Devil's Claw Conversion Kit for MCLK31613A



**Stainless Steel Pad Eye, Coated Wire & Spring Clip**

Two mounting options are available for our safety lanyards. Each features a 12 1/2" stainless wire lanyard connected to a captive stainless spring clip providing a working length of 14". The working load limit is 2600 lbs. Fits 1/4" & 5/16" chain only.

- SPA-880              Safety Lanyard with Padeye & Hook
- SPA-885              Safety Lanyard with Thru-Deck Eye and Hook

**Lofran's Chain Stopper**

The chain stopper is installed between the windlass and the bow roller in order to take the load off the windlass when the yacht is at anchor or when the anchor is stowed. It is for use with all-chain anchor systems.

LWP100CS      Stainless Steel, Manages 5/16" & 3/8" Chain Only

Chainstoppers, anchor swivels, snubbers, chain hooks and chain markers.



### Anchor Swivels

Our anchor swivels are constructed of rugged 18-8 stainless steel that is buffed to a polished finish. Their streamlined design ensures free running through bow rollers and chocks. The swivel also assists in the alignment of the anchor shaft into the bow roller. Use the chart below to find the size swivel that is best for your application.

### Windlass Clutch Handles

MF901007 10" Black alloy winch handle (Muir)  
 LWP72743 Floating 10" winch handle (Lofrans)

Item No.	Description	Working Load	Chain Size	Spread Between Eyes:		Pin Diameter:	
				Chain End	Anchor End	Chain End	Anchor End
SPA-801	Swivel, Small	1550 lbs.	1/4" - 5/16"	0.39"	0.62"	0.27"	0.39"
SPA-802	Swivel, Medium	4500 lbs.	5/16" - 7/16"	0.55"	0.82"	0.47"	0.51"
SPA-803	Swivel, Large	5880 lbs.	1/2"	0.62"	1.10"	0.55"	0.59"



### Snubbers & Chain Hooks

An anchor snubber is an important add-on when using an all chain rode. After setting the anchor, slip the hook onto a link of chain and tie off the 3-strand nylon tail. You can then let out additional chain with the windlass, which transfers the anchor load to the snubber from the windlass. This makes for an easier and quieter ride as the nylon tail will stretch slightly as the load of the boat on the anchor changes. We use high-strength ACCO chain hooks in our snubbers and offer these as separate items so you can build a snubber to fit your specifications.

SPA-SNUB1	Anchor Snubber for 1/4" Chain with 20' of 1/2" 3-Strand Nylon Line
SPA-SNUB2	Anchor Snubber for 5/16" Chain with 25' of 9/16" 3-Strand Nylon Line
SPA-SNUB3	Anchor Snubber for 3/8" Chain with 30' of 5/8" 3-Strand Nylon Line
SPA-HK1	Chain Hook Only for 1/4" Chain
SPA-HK2	Chain Hook Only for 5/16" Chain
SPA-HK3	Chain Hook Only for 3/8" Chain

### Chain Markers

Color-coded chain markers make it easy to keep track of chain deployment. Available in five colors: red, blue, green, yellow and white. Supplied in bags of 10 (5/16"), or 8 (3/8" and 1/2").

SPA-01.500.08R	Chain Markers, 5/16" Red (Bag of 10)
SPA-01.500.08B	Chain Markers, 5/16" Blue (Bag of 10)
SPA-01.500.08G	Chain Markers, 5/16" Green (Bag of 10)
SPA-01.500.08Y	Chain Markers, 5/16" Yellow (Bag of 10)
SPA-01.500.08W	Chain Markers, 5/16" White (Bag of 10)
SPA-01.500.10R	Chain Markers, 3/8" Red (Bag of 8)
SPA-01.500.10B	Chain Markers, 3/8" Blue (Bag of 8)
SPA-01.500.10G	Chain Markers, 3/8" Green (Bag of 8)
SPA-01.500.10Y	Chain Markers, 3/8" Yellow (Bag of 8)
SPA-01.500.10W	Chain Markers, 3/8" White (Bag of 8)
SPA-01.500.12R	Chain Markers, 1/2" Red (Bag of 8)
SPA-01.500.12B	Chain Markers, 1/2" Blue (Bag of 8)
SPA-01.500.12G	Chain Markers, 1/2" Green (Bag of 8)
SPA-01.500.12Y	Chain Markers, 1/2" Yellow (Bag of 8)
SPA-01.500.12W	Chain Markers, 1/2" White (Bag of 8)

**ANCHOR ROLLERS**



Photo: Intrepid Yachts

**Imtra's stainless steel anchor rollers are attractive and extremely durable.**

All Imtra anchor rollers are made of heavy-duty stainless steel and are extremely durable. Electro-polishing removes any surface impurities



Photo: MJM Yachts

and provides an attractive, smooth, bright finish that does not corrode and requires no maintenance. Many of our rollers are sized to hold specific anchor types and sizes. Please refer to the chart on page 49 to find the roller that

best fits your boat. Imtra also offers general purpose rollers and replacement roller wheels. For more information about these products, visit [www.imtra.com](http://www.imtra.com)



General Purpose Rollers

Replacement Roller Wheels



IABR-23



IABR-20



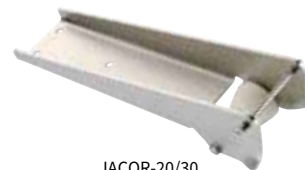
IABR-21  
(self launching)



IABR-22



IABRUCE-25  
(self launching)



IACQR-20/30

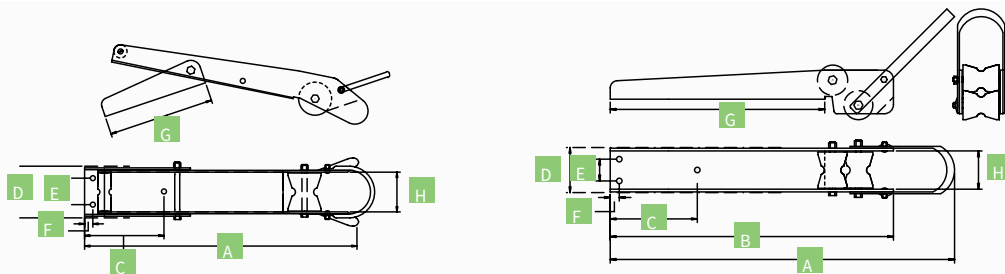


Bow rollers to fit the most popular anchors in a range of sizes and configurations.



### Roller Specifications

Many of our rollers are sized to hold specific anchor types and sizes. Use the diagrams and chart below to determine which anchor roller is best for you.



Item #	Anchor Type	A	B	C	D	E	F	G	H
IABR-20	Fluke-style anchors up to 35 lbs.	20"		6"	3 <sup>3</sup> / <sub>8</sub> "	2"	5 <sup>5</sup> / <sub>8</sub> "	14"	3"
IABR-21	Fluke anchors up to 20 lbs.	20 <sup>5</sup> / <sub>8</sub> "		6"	3 <sup>7</sup> / <sub>8</sub> "	2"	5 <sup>5</sup> / <sub>8</sub> "	8"	3"
IABR-22	Bruce, Delta® and fluke anchors up to 60 lbs.	23 <sup>11</sup> / <sub>16</sub> "	19 <sup>1</sup> / <sub>2</sub> "	6"	3 <sup>3</sup> / <sub>8</sub> "	1 <sup>1</sup> / <sub>2</sub> "	5 <sup>5</sup> / <sub>8</sub> "	14 <sup>13</sup> / <sub>16</sub> "	2 <sup>5</sup> / <sub>8</sub> "
IABR-22L	Extra-long version of IABR-22	27 <sup>11</sup> / <sub>16</sub> "	23 <sup>1</sup> / <sub>2</sub> "	6"	3 <sup>3</sup> / <sub>8</sub> "	1 <sup>1</sup> / <sub>2</sub> "	5 <sup>5</sup> / <sub>8</sub> "	18 <sup>13</sup> / <sub>16</sub> "	2 <sup>5</sup> / <sub>8</sub> "
IABR-23	CQR/Plow anchors from 30-60 lbs.	23"		6"	3"	1 <sup>1</sup> / <sub>2</sub> "	5 <sup>5</sup> / <sub>8</sub> "	17"	2 <sup>5</sup> / <sub>8</sub> "
IABRUCE-25	Bruce anchors from 11-44 lbs.	24 <sup>11</sup> / <sub>16</sub> "						16 <sup>11</sup> / <sub>16</sub> "	2 <sup>5</sup> / <sub>8</sub> "
IACQR-20	CQR plow anchors up to 45 lbs.	19 <sup>5</sup> / <sub>16</sub> "		6"	4"	2"	5 <sup>5</sup> / <sub>8</sub> "	14"	3 <sup>1</sup> / <sub>2</sub> "
IACQR-30	CQR plow anchors from 45-75 lbs.	29"						23"	4"
IADELTA-20	Delta anchors from 14-44 lbs.	18 <sup>1</sup> / <sub>2</sub> "		6"	3"	1 <sup>1</sup> / <sub>2</sub> "	5 <sup>5</sup> / <sub>8</sub> "	13 <sup>3</sup> / <sub>8</sub> "	2 <sup>1</sup> / <sub>4</sub> "
IADELTA-23	Delta anchors from 30-60 lbs.	23 <sup>5</sup> / <sub>16</sub> "		7 <sup>3</sup> / <sub>4</sub> "	4"	2"	5 <sup>5</sup> / <sub>8</sub> "	12 <sup>3</sup> / <sub>8</sub> "	3 <sup>1</sup> / <sub>2</sub> "
IAE-8	Fluke anchors up to 50 lbs.	18 <sup>1</sup> / <sub>2</sub> "		6 <sup>1</sup> / <sub>2</sub> "	6 <sup>1</sup> / <sub>2</sub> "			14"	3 <sup>5</sup> / <sub>16</sub> "
IA-KR1015	Rocna anchors from 22-33 lbs.	27"		6"	3"	1 <sup>1</sup> / <sub>2</sub> "	5 <sup>5</sup> / <sub>8</sub> "	20"	2 <sup>5</sup> / <sub>8</sub> "
IA-KR2025	Rocna anchors from 44-55 lbs.	32"		6"	3"	1 <sup>1</sup> / <sub>2</sub> "	5 <sup>5</sup> / <sub>8</sub> "	24"	2 <sup>5</sup> / <sub>8</sub> "

## REFERENCE GUIDE

## Our commitment to customer service and support.

Imtra's focus on service and extensive product knowledge are what set us apart. We have built our business on having



the products and replacement parts you need available for prompt delivery. The accessible staff at Imtra headquarters in New Bedford, Massachusetts has the training and experience to discuss your

requirements and answer any questions you may have.

Visit [www.imtra.com](http://www.imtra.com)

Imtra's website makes it easier than ever to find a wealth of product information and technical support! Search Imtra's website for maintenance tips, installation advice, downloadable owner's manuals, and much more.

Visit [www.imtralearningcenter.com](http://www.imtralearningcenter.com)

The Imtra Learning Center is a great resource for finding answers to your questions regarding marine equipment. Everything from windlass selection guides to trouble shooting tips and more can be found in the Learning Center. It's always being updated with more information, so be sure to check in regularly!



Photo: Grady-White

## Glossary of Anchoring Terms

**Capstan** – Often referred to as a drum, rope drum, or warping drum. The capstan is primarily used for hauling rope.

**Chainstopper** – Similarly, chain compressor. Located between the winch and bow roller. Secures chain and anchor and takes the load off the winch/windlass. Highly recommended for systems utilizing all chain and for semi-automatic rope/chain systems.

**Deck Clearance** – The allowable thickness of the deck where the windlass will be mounted.

**Free Fall** – Release of the winch clutch mechanism allowing the anchor and rode (chain or rope/chain) to run out freely with no engagement of winch gearbox or motor.

**Gypsy** – Often referred to as chainwheel or wildcat. A special wheel with pockets, to accommodate a specified chain size, for hauling up the chain and anchor. With automatic rope/chain systems the gypsy is designed to haul both rope and chain.

**Hauling** – Often referred to as weighing or lifting. The operation of lifting the anchor and rode.

**Horizontal** – Pertaining to the winch or windlass. Drive shaft, capstan and gypsy are positioned horizontally to the deck.

**Manual Override** – A means of manually cranking the winch to haul in the rode and anchor should a failure occur in the motor, gearbox or power supply.

**Power Rating** – Sometimes referred to as rated lift or maximum load. The maximum operating load that could be applied to the windlass (the load the windlass would normally be subjected to is substantially less).

**Retrieval Speed** – The speed at which the anchor rode will be hauled in by the windlass.

**Rode** – The line that secures the boat to the anchor. This may consist of all chain, all rope, or a combination of rope and chain.

**Self Launching Roller** – A roller that will deploy the anchor when the anchor rode is slackened.

**Vertical** – Pertaining to the winch or windlass. The drive shaft, capstan and gypsy are positioned vertically to the deck.

**Windlass** – A machine for raising a weight by winding a rope and/or chain around a drum or chainwheel, driven by a crank, motor, etc.

## Photo Credits

Imtra would like to thank the following boatbuilders, photographers, and companies for allowing us to use their images in this catalog:

American Tugs, Bayliss Boatworks, CW Hood Yachts, Cabo Yachts, Caliber Yachts, Cruiser Yachts, Fleming Yachts, Grady-White, Grand Banks, The Hinckley Company, Hunt Yachts, Hunter Yachts, Intrepid Yachts, Island Packet, Krogan Express, MJM Yachts, Nordhavn Yachts, Nordic Tugs, Onne Van der Wal Photography, Pearson Yachts, Sabre Yachts, Sea Ray Inc., Striper Boats, Shutterstock Inc., Sunsail USA, Tiara Yachts, Vicem Yachts, Viking Yachts.

For technical advice, parts, downloads and product details please visit [www.imtra.com](http://www.imtra.com)

### Conductor Sizes (Gauge) for 10% Voltage Drop

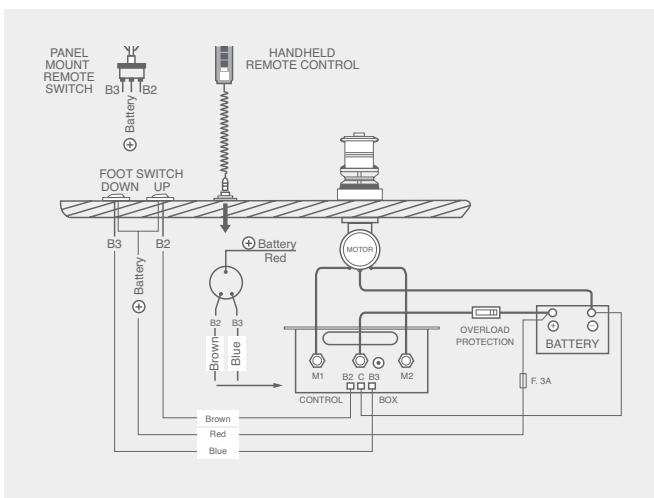
		12 Volts													
Total Current On Circuit		Length of conductor from source of current to windlass and back to source - in feet.													
	20	25	30	40	50	60	70	80	90	100	110	120	130	140	150
30 Amps	12	10	10	8	8	6	6	6	6	4	4	4	4	2	2
40 Amps	10	10	8	8	6	6	6	4	4	4	2	2	2	2	2
50 Amps	10	8	8	6	6	4	4	4	2	2	2	2	2	1	1
60 Amps	8	8	6	6	4	4	2	2	2	2	2	1	1	1	0
70 Amps	8	6	6	6	4	2	2	2	2	1	1	1	0	0	0
80 Amps	8	6	6	4	4	2	2	2	1	1	0	0	0	2/0	2/0
90 Amps	6	6	6	4	2	2	2	1	1	0	0	0	2/0	2/0	2/0
100 Amps	6	6	4	4	2	2	1	1	0	0	0	2/0	2/0	2/0	3/0

		24 Volts													
Total Current On Circuit		Length of conductor from source of current to windlass and back to source - in feet.													
	20	25	30	40	50	60	70	80	90	100	110	120	130	140	150
30 Amps	14	14	12	12	10	10	8	8	8	8	8	6	6	6	6
40 Amps	14	12	12	10	10	8	8	8	6	6	6	6	6	6	4
50 Amps	12	12	10	10	8	8	6	6	6	6	6	4	4	4	4
60 Amps	12	10	10	8	8	6	6	6	6	4	4	4	4	2	2
70 Amps	10	10	8	8	6	6	6	6	4	4	4	2	2	2	2
80 Amps	10	10	8	8	6	6	6	4	4	4	2	2	2	2	2
90 Amps	10	8	8	6	6	6	4	4	4	2	2	2	2	2	2
100 Amps	10	8	8	6	6	4	4	4	2	2	2	2	2	1	1

Based on minimum CM Area ©2003 American Boat & Yacht Council. In the event of a conflict between a voltage drop calculation for wiring sizes and these ampacity tables, use the larger wire size.

### TYPICAL WIRING DIAGRAM



IMTRA is a registered trademark of Imtra Corporation.  
 ACCO is a registered trademark of FKI Industries.  
 AUTOANCHOR is a trademark of RMSD Limited.  
 CQR and DELTA are registered trademarks of Lewmar, Ltd.  
 DANFORTH is a registered trademark of Rule Industries.  
 DELRIN is a registered trademark of E.I. du Pont de Nemours and Company.  
 Design: Sewell Creative Color Illustrations: mirtoart.com



Imtra Corporation  
 30 Samuel Barnett Boulevard, New Bedford, MA 02745 U.S.A.  
 Phone: 508.995.7000 Fax: 508.998.5359

Connect with us





30 Samuel Barnet Boulevard, New Bedford, MA 02745 U.S.A.  
Phone: 508.995.7000 Fax: 508.998.5359 E-mail: info@imtra.com



[www.imtra.com](http://www.imtra.com)

