

Installation Guide

For Hydraulic Thruster Models

SH100, SH160



SLEIPNER AS

P.O. Box 519

N-1612 Fredrikstad

Norway

www.sleipnergroun.com

DOCUMENT ID: 2746

REVISION: 27

DATE: 2021

LANGUAGE: EN

MI

Installation instructions

Planning Considerations and Precautions	3
Thruster Measurements	4
Thruster Specifications	5
Technical Specifications	5
Positioning of the tunnel/ thruster	6
Tunnel Length	7
Tunnel Installation in Sailboats.....	8
Water Deflection	9
Tunnel ends	10
Tunnel Installation.....	11 - 12
Stern Tunnel Installation.....	13

Thruster installation

Hydraulic Thruster Installation Considerations and Precautions..	14
.....	14
Technical Specifications	15
Technical Requirements / Hydraulic hose connections to motor	16
.....	16
Gear Leg & Motor Bracket Installation	17
Propeller Installation.....	18
Motor Installation	19
S-link Planning & Precautions	20
Control Panel Installation.....	21
Checklist for Hydraulic Thrusters.....	22

Service and Support 23

Product Spare Parts and Additional Resources 23

Warranty statement 23

Products

SH100/185T-U08 - SH100 Tunnel thruster, U08
 SH100/185T-U10 - SH100 Tunnel thruster, U10
 SH100/185T-U11 - SH100 Tunnel thruster, U11
 SH160/215T-U08 - SH160 Tunnel thruster, U08
 SH160/215T-U11 - SH160 Tunnel thruster, U11
 SH160/215T-U14 - SH160 Tunnel thruster, U14
 SH160/215T-U06 - SH160 Tunnel thruster, U06
 SH160/215T-U10 - SH160 Tunnel thruster, U10
 SH100/185T-U06 - SH100 Tunnel thruster, U06

DECLARATION OF CONFORMITY

MC_0020



Sleipner Motor AS
 P.O. Box 519, Arne Svendsensgt. 6-8
 N-1612 Fredrikstad, Norway

Declare that this product with accompanying standard control systems complies with the essential health and safety requirements according to:

DIRECTIVE 2013/53/EU
 DIRECTIVE 2014/30/EU
 DIRECTIVE 2014/35/EU

It is the installers responsibility

When installing Sleipner equipment follow the outlined regulations/ classification rules (electrical/ mechanical) according to international or special national regulations. Instructions in this guide cannot be guaranteed to comply with global electric/ mechanic regulations/ classification rules.

Follow all health and safety laws in accordance with their local outlined regulations/ classification rules.

Before installation, it is important that the installer reads this guide to ensure necessary acquaintance with the product.

The recommendations made in this manual are guidelines ONLY, and Sleipner Motor AS (Sleipner) strongly recommend that before installation, advice is obtained from a naval architect familiar with the particular vessel and regulations/ classifications.

This manual is intended to support educated/ experienced staff and is therefore not sufficient in all details for professional installation. *(NB: These instructions are only general instruction. If you are not skilled to do this work, please contact professional installers for assistance.)*

All electrical work must be done by a licensed professional.

Faulty installation of Sleipner products will render all warranty given by Sleipner Motor AS void.

MC_0038

EN

Planning Considerations and Precautions

MC_0113

- Do not install the thruster in a position where you need to cut a stiffener/ stringer/ support for the hull integrity without checking with the boat builder this can be done safely.
- The motor, its components, contacts/ plugs or other joints in the control cables must be mounted so they will remain dry at all times.
- We advise painting the gear house and propellers with anti-fouling. **(NB: Do not paint the anodes, sealing, rubber fittings or propeller shafts)**
- Do not finish the inside of the tunnel with a layer of gel-coat/ topcoat or similar. There is only room for a thin coat of primer and two layers of anti-fouling between the tunnel and the propellers.
- Keep installation within advised measurements. The entire surface is hard coated seawater resistant aluminium. Do not damage or penetrate the coat.
- Install the oil tank higher than the pumps to ensure enough gravity feed and pressure for feed ports. **(NB: The height of oil levels in the hydraulic tank should be higher than the connected hydraulic pumps.)**
- Find a suitable location for the hydraulic tank installation for future maintenance accessibility. There must be enough space around the oil tank to change filters, fill oil and inspect gauges and indicators.

EN

Hydraulic Thruster Installation Considerations and Precautions

MC_0009

Before installation, The installer must read this guide to ensure necessary acquaintance with this product.

- If the height of the room you are installing the Side-Power is limited, it can be installed horizontally or at any angle in-between.
- The motor must be handled with care. Do not rest on the drive shaft.

If an original Side-Power hydraulic system is NOT installed, please ensure the following:

- Install an oil filter to keep the oil clean.
- Fit an oil cooler or use an oil tank to ensure the maximum oil temperature is 43 - 50 degrees Celsius.
- Hydraulic thrusters are supplied with hydraulic motors only.
- The installed hydraulic system is the responsibility of the fitter/ installer and must be within the limitations outlined in this manual to ensure no damage is caused to the thruster.
- The hydraulic valve must have flow and pressure limits that are either set within or can be adjusted to the limits of the thrusters capability.
- We strongly advise that a shock valve is fitted and set to 10% - 15% above the chosen maximum pressure set in the valve. This will prevent the system from being damaged if the propellers are blocked for any reason.
- It is required that a device is installed to ensure that the drive direction cannot be suddenly changed, as this can severely damage the gear house. **(NB: By adding an electronic time-lapse/delay safety on the electric control system or by using a valve that has this type of protection built in will prevent this issue. *The required time delay is 1 second.)**

IMPORTANT

If installing S-link products DO NOT connect any other control equipment to the S-link controlled products except Sleipner original S-link products or via a Sleipner supplied interface product made for interfacing with other controls. Any attempt to directly control or at all connect into the S-link control system without the designated and approved interface will render all warranties and responsibilities for the complete line of Sleipner products connected void and null. If you are interfacing by agreement with Sleipner and through a designated Sleipner supplied interface, you are still required to also install at least one original Sleipner control panel to enable efficient troubleshooting if necessary.

MC_0265

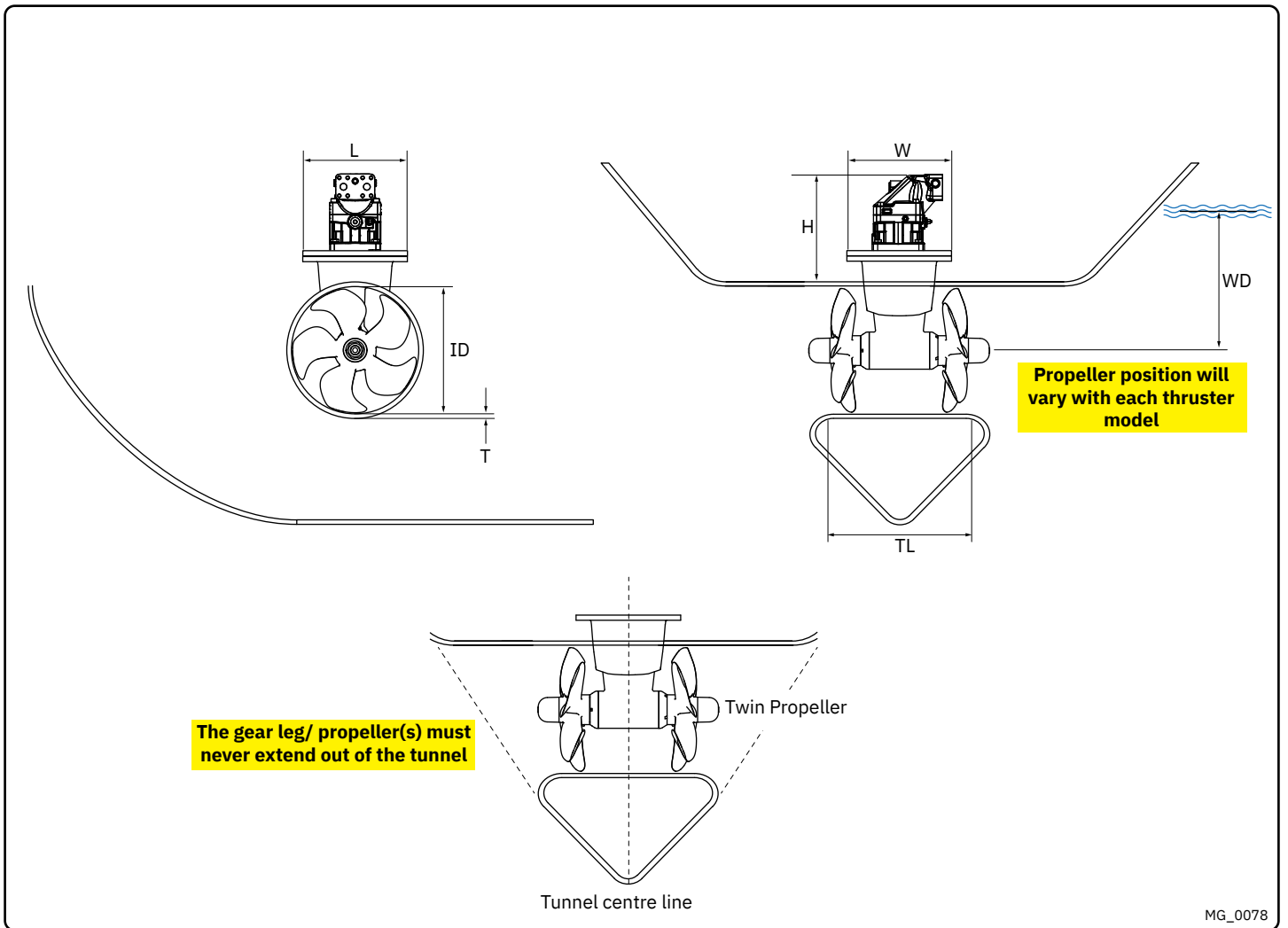

EN

Thruster Measurements

MC_0185

Measurement code	Measurement description	*100		*160		*240	
		mm	inch	mm	inch	mm	inch
ID	Internal tunnel diameter	185	7.28	215	8.46	250	9.84
H	Motor Height	215	8.46	195	7.68	235	9.25
W	Width	200	7.87	200	7.87	200	7.87
L	Length	215	8.46	195	7.68	235	9.25
WD	Water Depth	200	7.87	215	8.46	250	9.84
TL	Minimum tunnel length	170	6.69	280	11.02	300	11.81
TL (recommended)	Recommended tunnel length	340	13.39	560	22.05	600	23.62
T (min)	Minimum tunnel wall thickness	6	0.24	6	0.24	7	0.28
T (max)	Maximum tunnel wall thickness						

Description	* 100	* 160	* 240
Light duty thrust up to (kg * lbs)	100kg * 220lbs	160kg * 352lbs	240kg * 529lbs
Heavy duty thrust up to (kg * lbs)	80kg * 176lbs	140kg * 308lbs	220kg * 440lbs
Typical Boat Size (m * ft)	9m - 16m * 30ft - 34ft	11m - 19m * 35ft - 62ft	13m - 23m * 42ft - 75ft
Propulsion System	Twin	Twin	Twin Counter Rotating
Power (kw * Hp)	6.9kw * 9.3hp	10kw * 13.4hp	14.9kw * 20hp
Weight (kg * lbs)	7.8 kg * 17.19 lbs	11.4 kg * 25.13 lbs	13.5 kg * 29.76 lbs
Lubrication	Sealed	Sealed	Sealed

- Motor:** Hydraulic type (specifications above).
- Gear house:** Seawater resistant bronze. Ball-bearing at propeller shaft and a combination of ball bearing and slide bearing at drive shaft.
- Gears:** Hardened precision gears
- Lubrication:** Oil bath from tank (gear oil EP 90)
- Bearings:** Angular contact ball bearing at propeller shaft and combination of ball bearing and needle bearing at drive shaft.
- Motor bracket:** Seawater resistant aluminium, galvanically insulated from the motor.
- Tunnel:** Cross spun with rowing G.R.P tunnel
Steel & aluminium tunnels available at request.
- Propeller:** SH 100/ SH 160/ SH 240/ SH 320/ SH 360: 5-blade skewback "Q-prop" propeller, fibreglass reinforced composite.
SH 420/ SH 550 Symmetrical 4 blade kaplan propeller, fibreglass reinforced composite.
- Safety:** Flexible coupling between hydraulic-motor and drive shaft protects gear system if propeller jams.

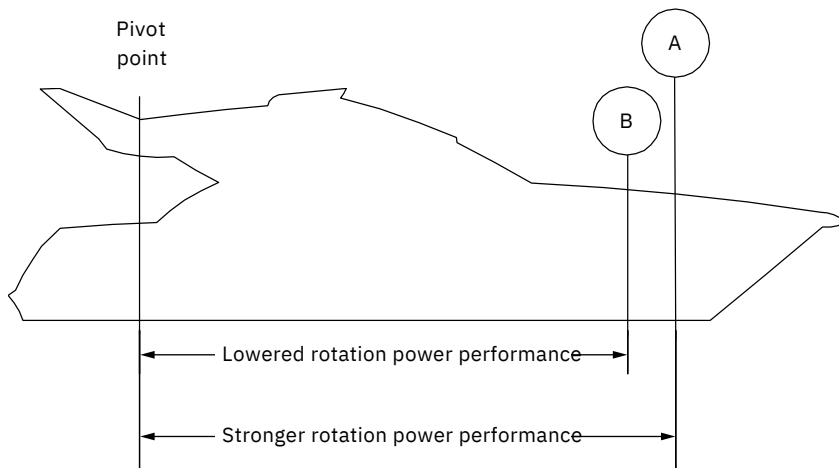
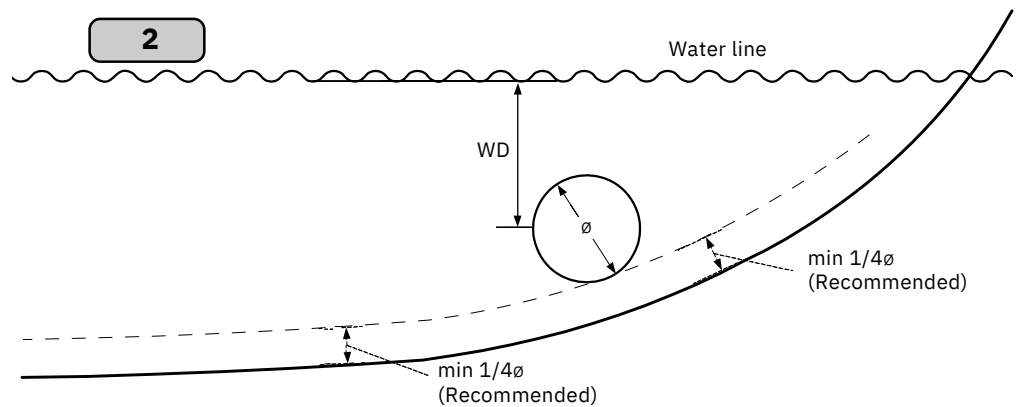
1**2**

MG_0001

EN

Positioning of the tunnel / thruster

MC_0003

Aim to install the thruster as far forward as possible (1)

Due to the leverage effect around the boats' pivot point. The distance difference from the boat pivots' point to the thruster will determine the amount of real rotation power for the boat.

Aim to install the thruster as deep as possible under the waterline (2)

Deeper installations prevent air from being sucked into the tunnel from the surface, resulting in reduced thrust performance and increase noise levels during operation. Deeper installations increase water pressure for maximum efficiency from the thruster.

The centre of the tunnel should be a minimum of 1 x the tunnel diameter below the waterline. The installer must make evaluations based on thruster performance, boat type and operating conditions. As a general recommendation, the position of the tunnel should not be a minimum of 1/4 of the diameter of the tunnel from the boat keel. **(NB: This can be overlooked depending on the installation methods defined in this manual.)**

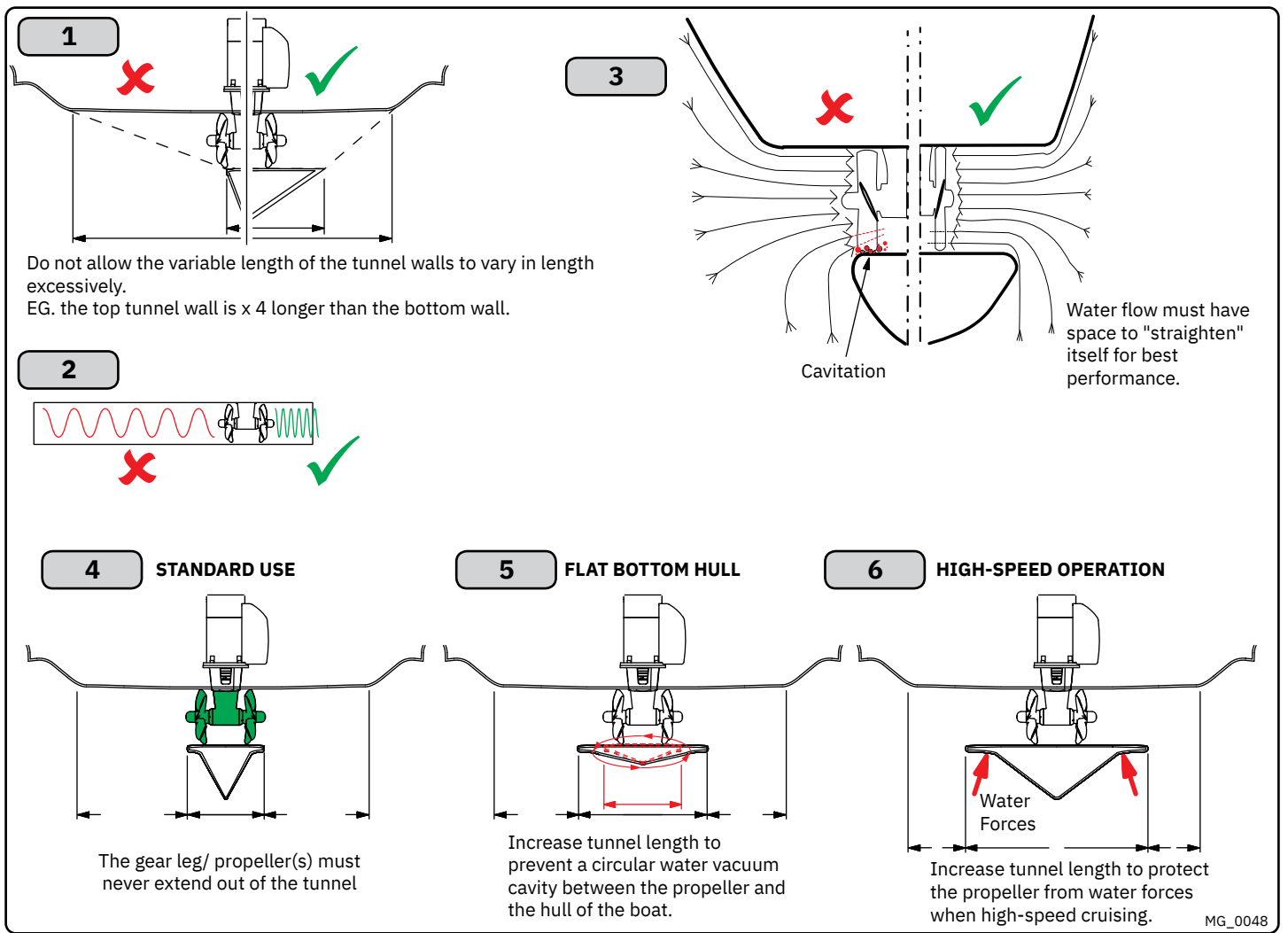

EN **Tunnel Length** MC_0003

Optimal tunnel length

Achieving the correct tunnel length depends on many factors from the hull type, operation and environmental conditions. Tunnels should avoid being longer than 4 x the tunnel diameter as this will reduce thruster performance. **(NB: Installing long length tunnels can flex/bend over time and may require additional support. Consult with a naval architect.)**

1. Do not allow the variable length of the tunnel walls to vary in length excessively.
EG. the top tunnel wall is x 4 longer than the bottom wall.
2. If the tunnel is too long, the friction inside will reduce the water speed and thereby the thrust.
3. If the tunnel is too short (typically only in the bottom section of the tunnel) cavitation problems can occur as water flow will not be able to "straighten" itself before reaching the propeller. This cavitation will reduce performance and increase noise during operation.

Thruster within the tunnel

It is important the propellers and the lower unit/ gear leg must be entirely inside the thruster tunnel. Propellers that protrude from the tunnel will not perform as intended.

4. **Standard Use**
Tunnel length must be long enough to ensure the propellers are not extruding the tunnel.
5. **Flat Bottom Hull**
Tunnel lengths must be longer than the standard measurement outlined within the manual to ensure a circular vacuum is not created between the thruster and the bottom of the boat.
6. **High-Speed Boats**
Tunnel lengths must be increased to protect the propeller from damage when crashing against the water surface during high-speed cruising. **(NB: This can include the length of a spoiler)**

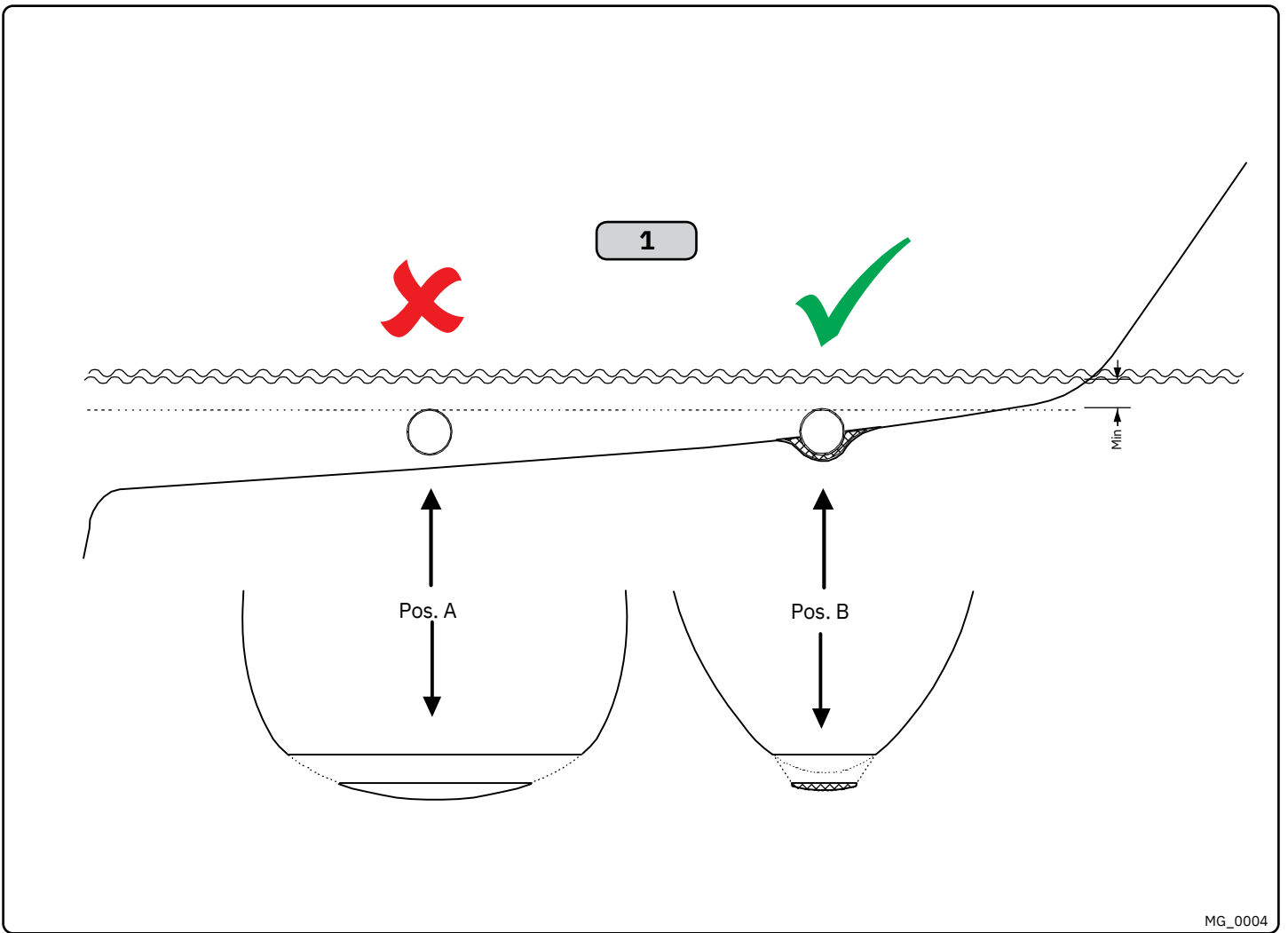

MG_0004

EN

Tunnel installation in sailboats

MC_0003

Some sail boats have a flat bottom and shallow draft in the bow section. This can make installing the thruster as far forward from the boats main pivot point difficult. **(Fig. 1).**

However, it is possible to install a tunnel thruster in most sail boats, even when the hull does not directly support the fitting of a tunnel.

Instead fit the tunnel halfway into the underneath section of the existing hull. Strengthen it with a deflector/ spoiler directing the water flow around the tunnel. This will allow installation of the thruster in the proper position on the boat, maintaining the reliability and space advantages of the tunnel thruster.

This installation is being used by some of the world's largest sail boat builders and has proven to give little to no speed loss during normal cruising. This can also be an installation method for flat bottomed barges to avoid extremely long tunnels and large oval tunnel openings in the hull.

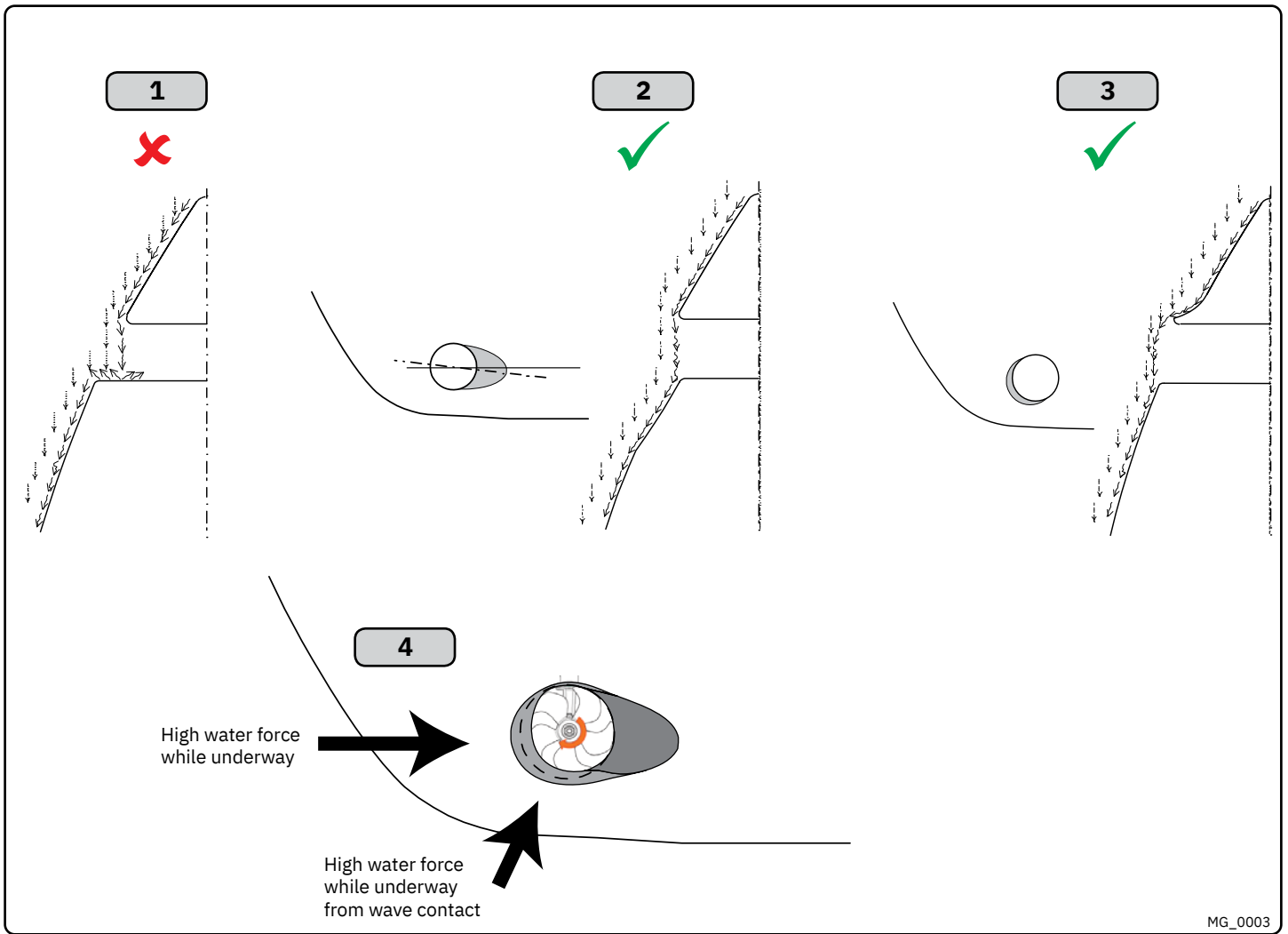

MG_0003

EN

Water Deflection

MC_0003

1. A possible problem in sail boats or fast powerboats is that a non-rounded surface can generate drag from the back face of the tunnel, as it creates a "flat" area facing the flow of water **(1)**.

This problem can be solved in two different ways, depending on what is possible or easier to perform.

2. The best solution which generally reduces the most drag is to make a recess in the hull at the back of the tunnel. As the back face is removed water can flow freely past the tunnel entry. The depth and shape of this recess will depend on the boat and the angle facing up/ down aft of the tunnel insert. Normally it is angled slightly down because of the water flow on this area **(2)**.
3. Making a deflector/ spoiler in front and underneath the tunnel can also reduce damage to the thruster and drag. The deflector/ spoiler will push the water flow out from the hull so water can pass by the back face of the tunnel. The shape and size of this deflector/ spoiler will depend on the hull shape. The easiest way of making the deflector/ spoiler is to retain a part of the lower forward area of the tunnel while installing the tube. Use this area as support to mould a soft curve/spoiler shape from the hull. **(3)**.
4. The thruster propeller can spin (passively) producing noise while sailing or cruising as water is forced through the tunnel. Water-flow directed through the tunnel at high speeds, during turning or as the boat bumps waves while underway can also damage the thruster **(4)**.

(NB: As a rule, you should not see the back face of the tunnel when standing directly in front of the boat looking aft.)

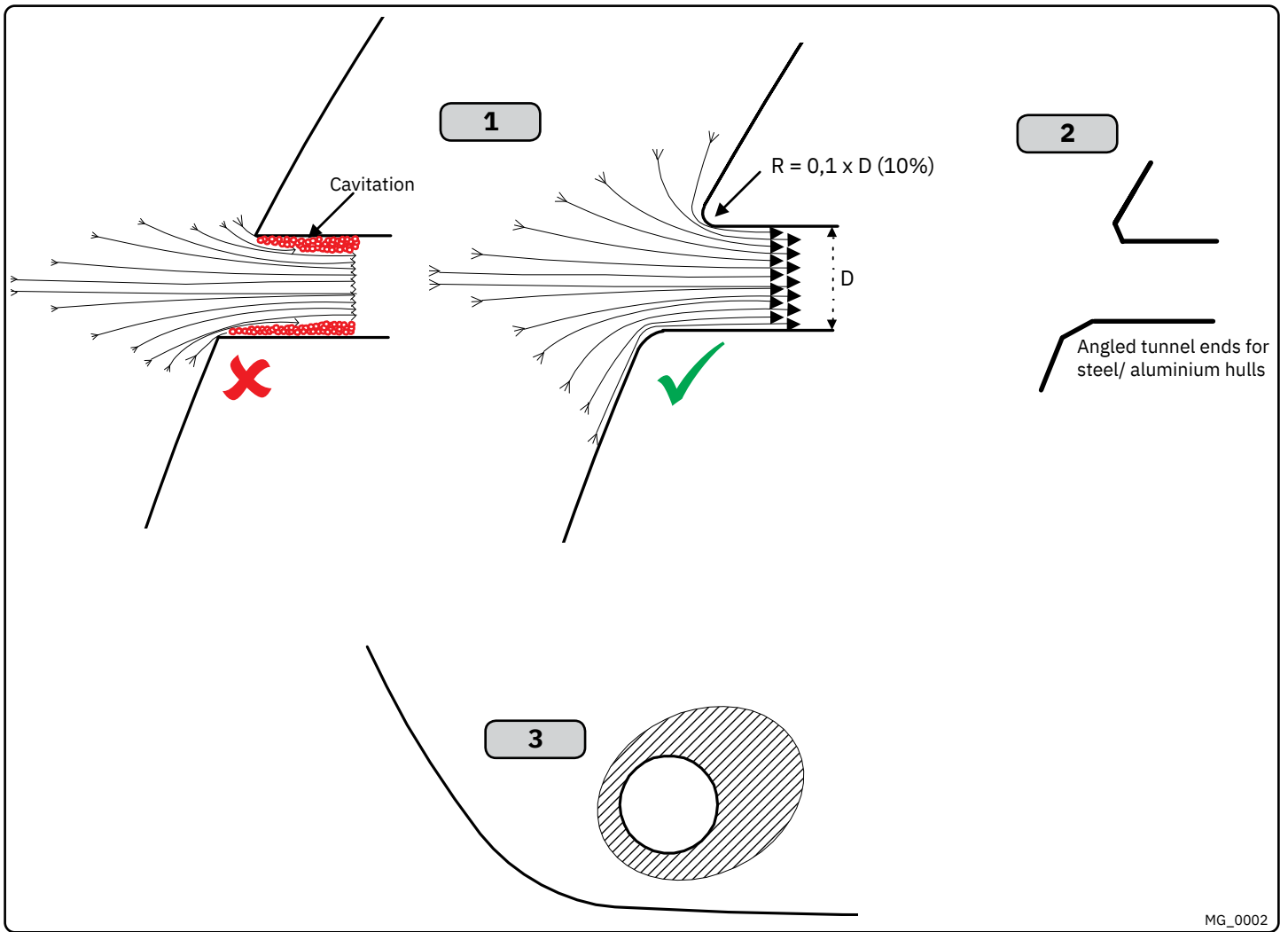

Rounded tunnel ends will maximise thrust and minimise noise and cavitation.

For best performance round the tunnel connection to the hull-side as much as possible. The minimum rounding has a radius of 10% of the diameter of the tunnel.

Significant advantages of a rounded tunnel over a sharp tunnel to hull connections are:

1. A rounded tunnel end will prevent the creation of turbulence/ cavitation created from a sharp tunnel end when water passes by the tunnel.
 - The turbulence/ cavitation will block the outer area of the tunnel and thereby reduces the effective tunnel diameter and thrust.
 - Turbulence/ cavitation on the propeller will lessen the thrusters performance and create excess noise.
2. For steel/ aluminium hulls angled tunnel ends also offer similar performance as a rounded connection.
3. A rounded tunnel end makes the thruster draw water from along the hull-side, creating a vacuum that will suck the boat sideways and thereby give additional thrust.
 - With a sharp tunnel end, the thruster will be unable to take water from along the hull-side, and you will not gain the desired vacuum and additional thrust. This "free" extra thrust in optimal installations be 30 - 40% of the total thrust.

(NB: A Side-power thruster propeller does not produce cavitation at working speed. Therefore, any cavitation and cavitation noise in the tunnel will be caused during improper tunnel installation.)

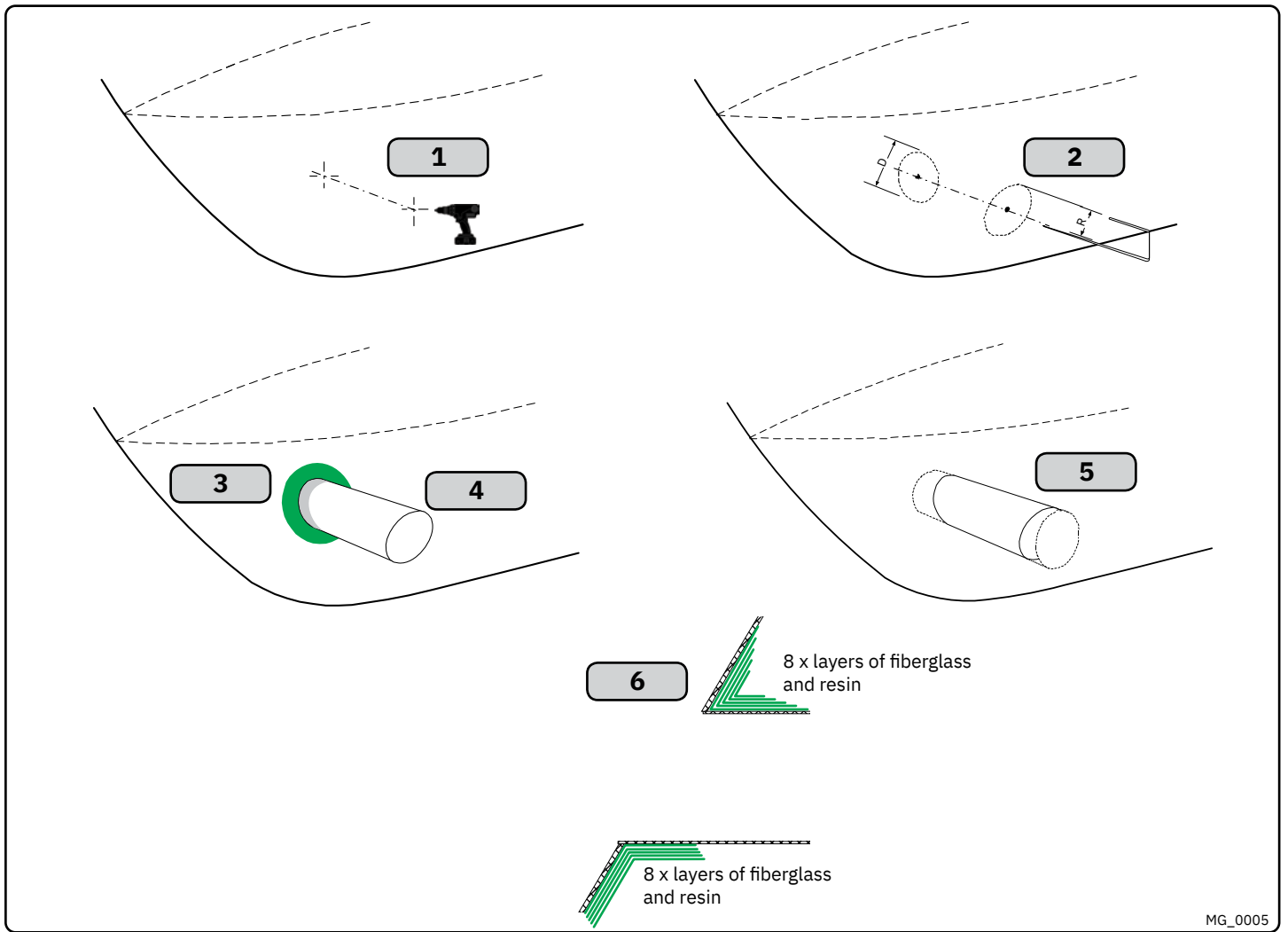

MG_0005

EN

Tunnel Installation

MC_0003

IMPORTANT

We recommend that a professional does the fibreglass, steel or aluminium fitting of the tunnel. These instructions are only general instructions and do not explain in any way the details of fibreglass work. Problems caused by faulty installation of the tunnel, are the installers full responsibility.

1. Find the position in the boat considering the information earlier in this manual and the applicable measurements for the thruster model you are installing. Mark the centre of the tunnel on both sides of the hull. Drill a hole horizontally at these marks.
2. Mark the circle for the tunnel opening (outside diameter of the tunnel) and cut the hole.
3. Grind off the gel coat to the "real fibreglass" area 12cm around the hole on both inside and outside the hull to cast the tunnel to the hull (**Fig. 3**).
4. Insert the tunnel and mark its shape to fit the hull. (**NB: if you are installing with a deflector/ spoiler, leave a part of the tunnel in the front and underside of the tunnel that will cover the back face.**)
5. Cut the tunnel ends to the desired shape and lightly sand its surface. Clean the area with acetone or similar where you are going to apply fibreglass. (**NB: Do not cast or add fibreglass to the area were the thruster will be placed.**)
6. Cast the tunnel to the inside of the hull, use at least eight layers of 300g fibreglass and resin, preferably alternating mat and rowing types of fibreglass. To round the tunnel ends to a 10% radius make further layers inside to preserve the desired hull thickness.

(**NB: Ensure gaps between the tunnel and the hull are completely filled with resin/ fibreglass. In areas where you can not access to make layers of resin/ fibreglass, a resin/ fibreglass mixture must be used in that area.**)

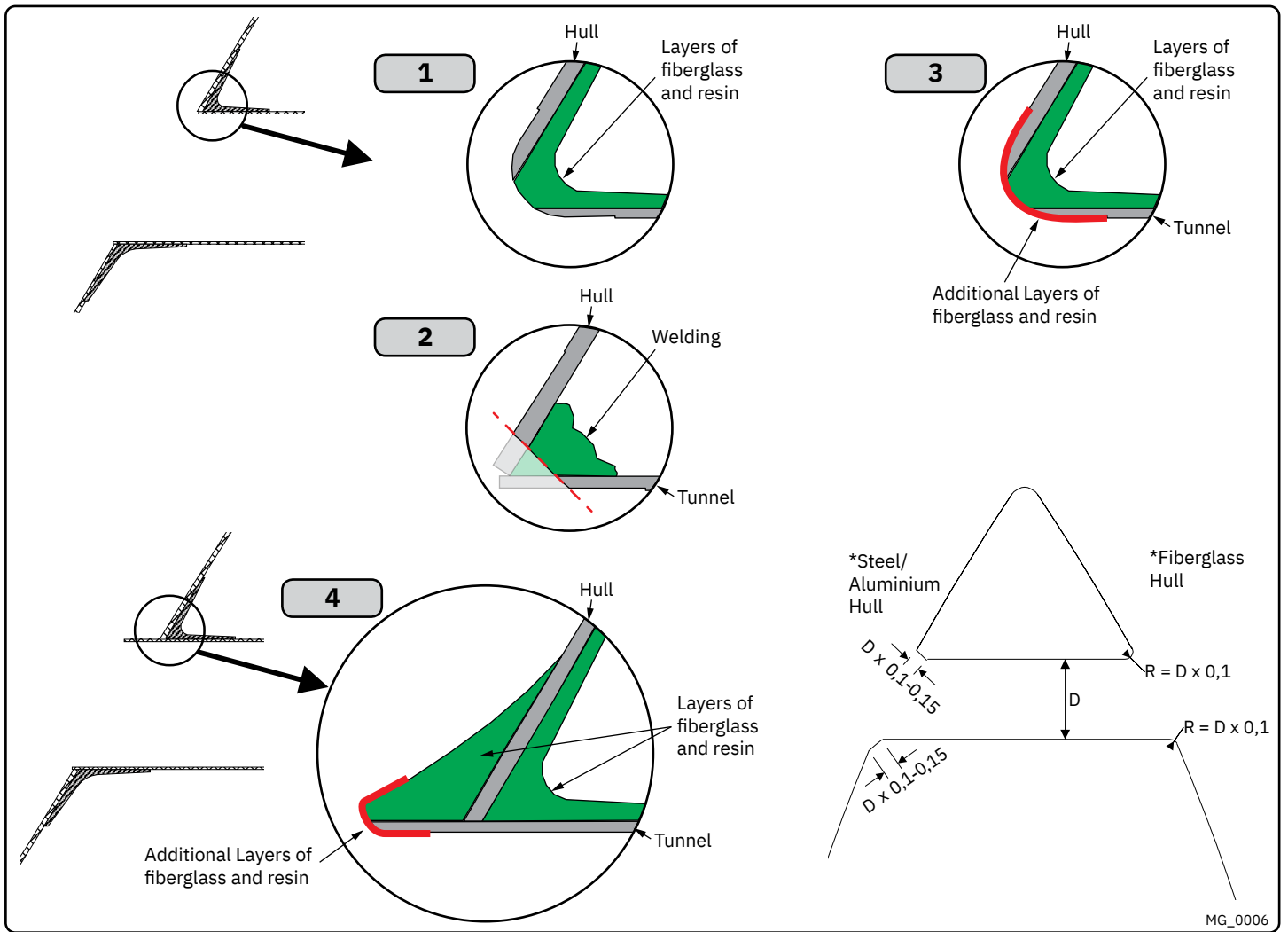

EN

Tunnel Installation

MC_0003

With tunnel installed and cast.

1. Round the edges with a radius of 10% of the tunnel diameter.
2. For steel/ aluminium hulls make a slope with a length of 10-15% of the tunnel diameter.
(NB: If this is not possible, round the tunnel end as much as possible.)
3. Additionally cast two layers on the outside of the tunnel/ hull in a 10cm area
4. Follow the same method if making the deflector/ spoiler.

You must apply gel coat to areas you have grounded/ moulded to make waterproof. These areas allow water access to the hull which is typically not waterproof without these applications outside. **(NB: All original Side-Power tunnels are fully waterproof when delivered except in the areas where you have cut and bonded it to the hull.)**

IMPORTANT

Avoid all casting where the motor-bracket is to be placed, as this will cause misfit and possible failure to the gear house.

Stern thruster installation has extra considerations and precautions and thruster installation procedures.

See the attached manual supplied in the stern thruster kit

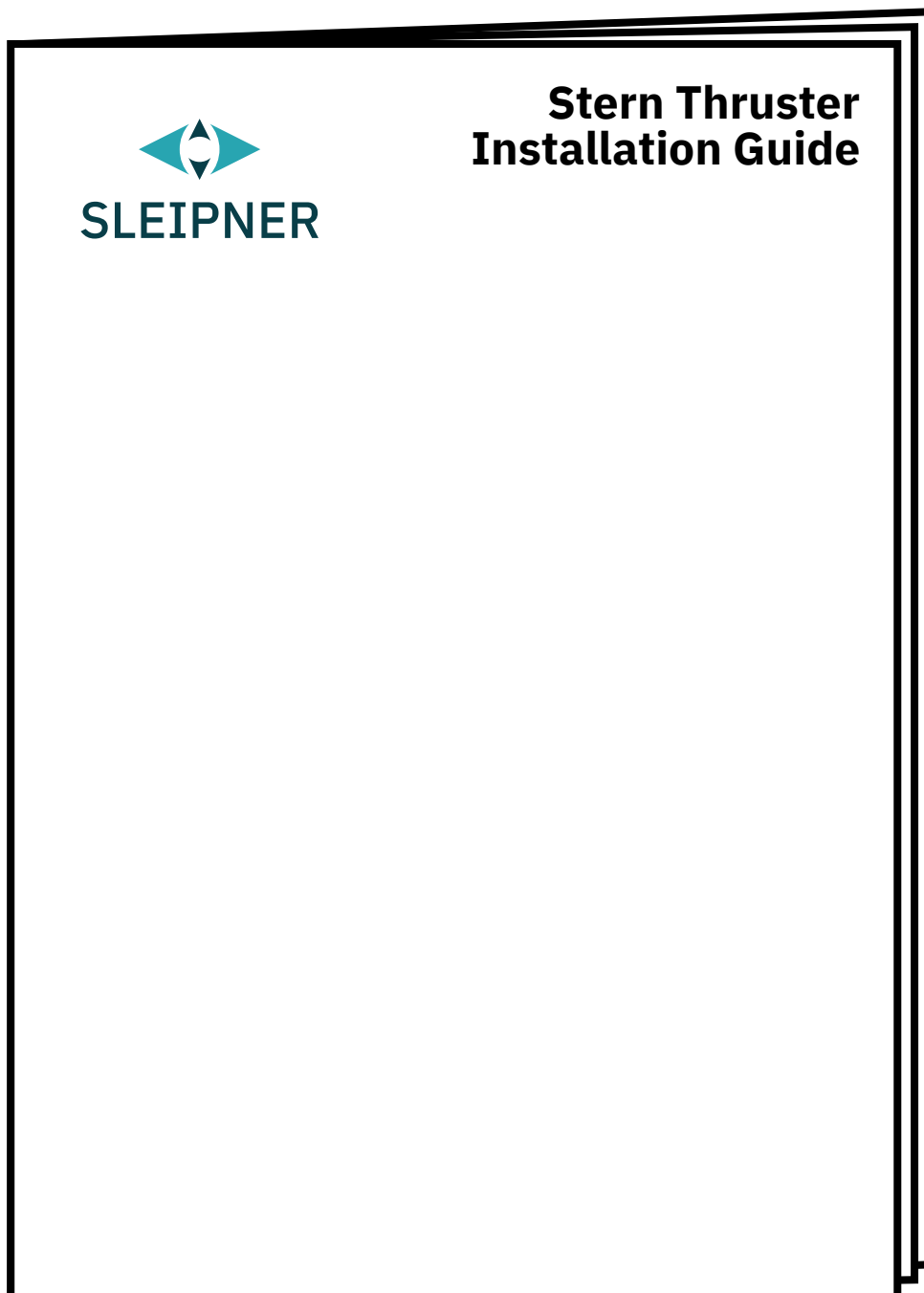

It is the installers responsibility

When installing Sleipner equipment follow the outlined regulations/ classification rules (electrical/ mechanical) according to international or special national regulations. Instructions in this guide cannot be guaranteed to comply with global electric/ mechanic regulations/ classification rules.

Follow all health and safety laws in accordance with their local outlined regulations/ classification rules.

Before installation, it is important that the installer reads this guide to ensure necessary acquaintance with the product.

The recommendations made in this manual are guidelines ONLY, and Sleipner Motor AS (Sleipner) strongly recommend that before installation, advice is obtained from a naval architect familiar with the particular vessel and regulations/ classifications.

This manual is intended to support educated/ experienced staff and is therefore not sufficient in all details for professional installation. *(NB: These instructions are only general instruction. If you are not skilled to do this work, please contact professional installers for assistance.)*

All electrical work must be done by a licensed professional.

Faulty installation of Sleipner products will render all warranty given by Sleipner Motor AS void.

MC_0038

EN

Planning Considerations and Precautions

MC_0113

- Do not install the thruster in a position where you need to cut a stiffener/ stringer/ support for the hull integrity without checking with the boat builder this can be done safely.
- The motor, its components, contacts/ plugs or other joints in the control cables must be mounted so they will remain dry at all times.
- We advise painting the gear house and propellers with anti-fouling. **(NB: Do not paint the anodes, sealing, rubber fittings or propeller shafts)**
- Do not finish the inside of the tunnel with a layer of gel-coat/ topcoat or similar. There is only room for a thin coat of primer and two layers of anti-fouling between the tunnel and the propellers.
- Keep installation within advised measurements. The entire surface is hard coated seawater resistant aluminium. Do not damage or penetrate the coat.
- Install the oil tank higher than the pumps to ensure enough gravity feed and pressure for feed ports. **(NB: The height of oil levels in the hydraulic tank should be higher than the connected hydraulic pumps.)**
- Find a suitable location for the hydraulic tank installation for future maintenance accessibility. There must be enough space around the oil tank to change filters, fill oil and inspect gauges and indicators.

EN

Hydraulic Thruster Installation Considerations and Precautions

MC_0009

Before installation, The installer must read this guide to ensure necessary acquaintance with this product.

- If the height of the room you are installing the Side-Power is limited, it can be installed horizontally or at any angle in-between.
- The motor must be handled with care. Do not rest on the drive shaft.

If an original Side-Power hydraulic system is NOT installed, please ensure the following:

- Install an oil filter to keep the oil clean.
- Fit an oil cooler or use an oil tank to ensure the maximum oil temperature is 43 - 50 degrees Celsius.
- Hydraulic thrusters are supplied with hydraulic motors only.
- The installed hydraulic system is the responsibility of the fitter/ installer and must be within the limitations outlined in this manual to ensure no damage is caused to the thruster.
- The hydraulic valve must have flow and pressure limits that are either set within or can be adjusted to the limits of the thrusters capability.
- We strongly advise that a shock valve is fitted and set to 10% - 15% above the chosen maximum pressure set in the valve. This will prevent the system from being damaged if the propellers are blocked for any reason.
- It is required that a device is installed to ensure that the drive direction cannot be suddenly changed, as this can severely damage the gear house. **(NB: By adding an electronic time-lapse/delay safety on the electric control system or by using a valve that has this type of protection built in will prevent this issue. *The required time delay is 1 second.)**

IMPORTANT

If installing S-link products DO NOT connect any other control equipment to the S-link controlled products except Sleipner original S-link products or via a Sleipner supplied interface product made for interfacing with other controls. Any attempt to directly control or at all connect into the S-link control system without the designated and approved interface will render all warranties and responsibilities for the complete line of Sleipner products connected void and null. If you are interfacing by agreement with Sleipner and through a designated Sleipner supplied interface, you are still required to also install at least one original Sleipner control panel to enable efficient troubleshooting if necessary.

MC_0265

Thruster model	Motor type		60 %		80 %		100 %		
			Flow	Pressure	Flow	Pressure	Flow	Pressure	
SH 100	U6	L/min -Bar	18.8	103	21.7	137	24.2	172	
		USG-PSI	5.0	1494	5.7	1987	6.4	2494	
	U8	L/min -Bar	25.5	77	29.9	103	32.3	129	
		USG-PSI	6.6	1117	7.6	1494	8.5	1871	
	U10	L/min -Bar	31.3	62	36.1	82	40.4	103	
		USG-PSI	8.3	899	9.5	1189	10.7	1494	
SH 160	U6	L/min -Bar	18.6	150	21.5	200	24	250	
		USG-PSI	4.9	2175	5.7	2900	6.3	3625	
	U8	L/min -Bar	24.8	112	28.6	150	32.0	187	
		USG-PSI	6.6	1624	7.6	2175	8.5	2712	
	U10	L/min -Bar	31.0	82	35.8	120	40.0	150	
		USG-PSI	8.2	1305	9.5	1740	10.6	2172	
	U11	L/min - Bar	34.1	82	39.3	109	44.0	136	
		USG-PSI	9.0	1189	10.4	1581	11.6	1972	
	U14	L/min -Bar	43.1	64	49.7	86	55.6	107	
		USG-PSI	11.4	928	13.1	1247	14.7	1552	
	SH 240	U8	L/min -Bar	19.1	217	21.4	275	21.4	275 ¹⁾
			USG-PSI	5.05	3147	5.65	3988	5.65	3988 ¹⁾
U10		L/min -Bar	23.8	174	27.5	232	30	275 ²⁾	
		USG-PSI	6.29	2523	7.23	3364	7.93	3988 ²⁾	
U11		L/min -Bar	26.2	158	30.2	211	33.8	264	
		USG-PSI	6.9	2291	8.0	3060	8.9	3828	
U14		L/min -Bar	33.1	124	38.2	166	42.7	207	
		USG-PSI	8.7	1798	10.1	2407	11.3	3002	
U16		L/min -Bar	38.1	109	44.0	145	49.2	181	
		USG-PSI	10.1	1581	11.6	2103	13.0	2625	
U19		L/min -Bar	45.1	92	52.1	122	58.3	153	
		USG-PSI	11.9	1334	13.8	1769	15.4	2219	
SH320	U11	L/min -Bar	23.8	249	24.9	274	24.9	274 ³⁾	
		USG-PSI	6.29	3611	6.58	3973	6.58	3973 ³⁾	
	U14	L/min -Bar	30.1	196	34.7	261	35.6	274 ⁴⁾	
		USG-PSI	7.95	2842	9.17	3785	9.41	3973 ⁴⁾	
	U16	L/min -Bar	34.6	171	39.9	229	43.7	274 ⁵⁾	
		USG-PSI	9.14	2480	10.54	3321	11.55	3973 ⁶⁾	
	BA16	L/min -Bar	33.8	172	39.0	230	43.6	287	
		USG-PSI	8.93	2494	10.30	3335	11.52	4162	
	U19	L/min -Bar	41.0	144	47.3	193	52.9	241	
		USG-PSI	10.83	2088	12.50	2799	13.98	3495	
	BA19	L/min -Bar	40.1	145	46.3	194	51.8	242	
		USG-PSI	10.59	2103	11.44	2813	13.69	3509	
U23	L/min -Bar	49.4	121	57	162	63.8	202		
	USG-PSI	13.05	1755	15.06	2349	16.86	2929		
SH360	U19	L/min -Bar	46.5	177	53.7	236	55	248 ⁵⁾	
		USG-PSI	12.3	2567	14.17	3423	14.53	3597 ⁵⁾	
	BA19	L/min -Bar	45.3	176	52.3	234	58.5	293	
		USG-PSI	11.97	2553	13.82	3394	15.45	4250	
	U23	L/min -Bar	56.3	146	65.1	195	310	310 ⁷⁾	
		USG-PSI	14.88	2118	17.2	2828	81.89	4496 ⁷⁾	
	BA23	L/min -Bar	54.5	146	62.3	196	70.3	245	
		USG-PSI	14.4	2118	16.46	2843	18.57	3553	
SH400	U19	L/min -Bar	43.5	195	50.2	260	54.2	302 ⁸⁾	
		USG-PSI	11.49	2828	13.26	3771	14.32	4380 ⁸⁾	
	BA23	L/min -Bar	52.3	163	60.4	218	67.5	272	
		USG-PSI	13.82	2364	15.96	3162	17.83	3945	
SH 420	U26	L/min -Bar	44.7	188	51.6	251	56.2	298 ⁹⁾	
		USG-PSI	11.81	2726	13.63	3640	14.85	4321 ⁹⁾	
	U29	L/min -Bar	49.8	169	57.6	225	64.3	281	
		USG-PSI	13.16	2450	15.22	3263	16.99	4075	
	BA32	L/min -Bar	48.4	151	55.8	202	62.4	252	
		USG-PSI	12.78	2190	14.74	2929	16.49	3654	
	U33	L/min -Bar	56.1	148	64.7	198	72.4	247	
		USG-PSI	14.82	2146	17.09	2871	19.13	3582	
	U37	L/min -Bar	62.1	132	71.8	176	80.2	220	
		USG-PSI	16.41	1914	18.97	2552	21.19	3190	
	BA40	L/min -Bar	61	121	70.4	161	78.7	202	
		USG-PSI	16.12	1755	18.6	2335	20.79	2929	
SH550	BA40	L/min -Bar	69.8	158	80.5	211	90	264	
		USG-PSI	18.44	2291	21.27	3060	23.78	3828	
	P42	L/min -Bar	84.2	152	97.2	203	108.7	254	
		USG-PSI	22.25	2204	25.68	2944	28.72	3683	
	G45	L/min -Bar	89.5	142	103.4	190	115.6	237	
		USG-PSI	23.65	2059	27.32	2755	30.54	3437	
	BA45	L/min -Bar	77.8	139	89.9	185	100.5	232	
		USG-PSI	20.56	2016	23.75	2683	26.55	3364	
	U50	L/min -Bar	95	128	109.7	171	122.7	213	
		USG-PSI	25.10	1856	28.98	2480	32.42	3089	
	P52	L/min -Bar	105.1	124	121.4	166	135.7	207	
		USG-PSI	27.77	1798	27.77	2407	35.85	3002	
	BA60	L/min -Bar	104.6	106	120.8	141	135.1	176	
		USG-PSI	27.64	1537	31.92	2045	35.69	2552	

- 1) Max. thrust: 182kg
2) Max. thrust: 228kg
3) Max. thrust: 211kg
4) Max. thrust: 269kg
5) Max. thrust: 302kg
6) Max. thrust: 307kg
7) Max. thrust: 310kg
8) Max. thrust: 370kg
9) Max. thrust: 399kg

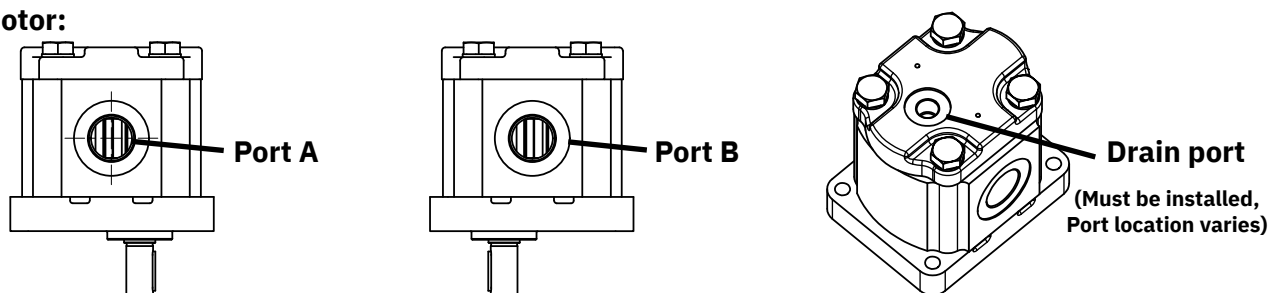
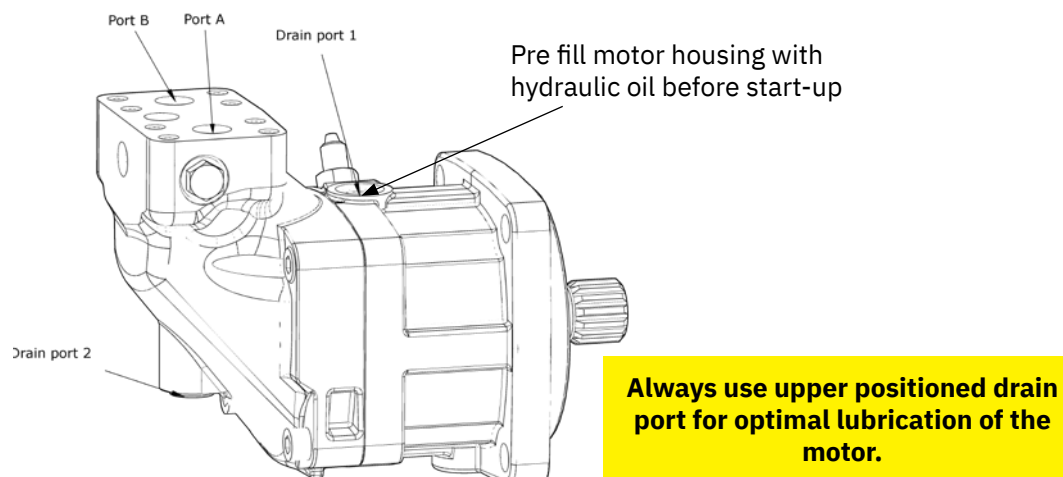
U, P & G-motor:**BA-motor:**

Motor type	Port A/B**	Port flange threads	Drain port
U6	1/2" BSP	—	1/4" BSP
U8	1/2" BSP	—	1/4" BSP
U10	3/4" BSP	—	1/4" BSP
U11	3/4" BSP	—	1/4" BSP
U14	3/4" BSP	—	1/4" BSP
U16	3/4" BSP	—	1/4" BSP
U19	3/4" BSP	—	1/4" BSP
U26	3/4" BSP	—	1/4" BSP*
U29	3/4" BSP	—	1/4" BSP*
U33	3/4" BSP	—	1/4" BSP*
U37	3/4" BSP	—	1/4" BSP*
U37	3/4" BSP	—	1/4" BSP*
U50	1" BSP	—	1/4" BSP*
P42	1" 3000 PSI SAE J518/ ISO 6162 Code 61	3/8-16 UNC-2B, 22 deep	1/4" BSP*
P52	1 1/2" 3000 PSI SAE J518/ ISO 6162 Code 61	M12 x 1,75, 19 deep	1/4" BSP*
G45	1 1/4" BSP	—	1/4" BSP*
BA16	1.1/16" - 12UN-2B	—	9/16" UNF-18
BA19	3/4" BSP	—	3/8" BSP*
BA32/ BA23	1/2" 6000 PSI SAE J518/ ISO 6162 Code 62	5/16-18 UNC-2B, 18 deep	3/4" UNF-16
BA40	3/4" 6000 PSI SAE J518/ ISO 6162 Code 62	3/8-16 UNC-2B, 20 deep	3/4" UNF-16
BA45	3/4" 6000 PSI SAE J518/ ISO 6162 Code 62	3/8-16 UNC-2B, 21 deep	3/4" UNF-16
BA60	3/4" 6000 PSI SAE J518/ ISO 6162 Code 62	3/8-16 UNC-2B, 22 deep	7/8" UNF-16

* Drain port connector must not extend internally beyond 10,5mm from end face.

** Use only parallel threaded adaptors, preferably with soft seal. Do not use plumbing tape, hemp, tread sealant or similar products.

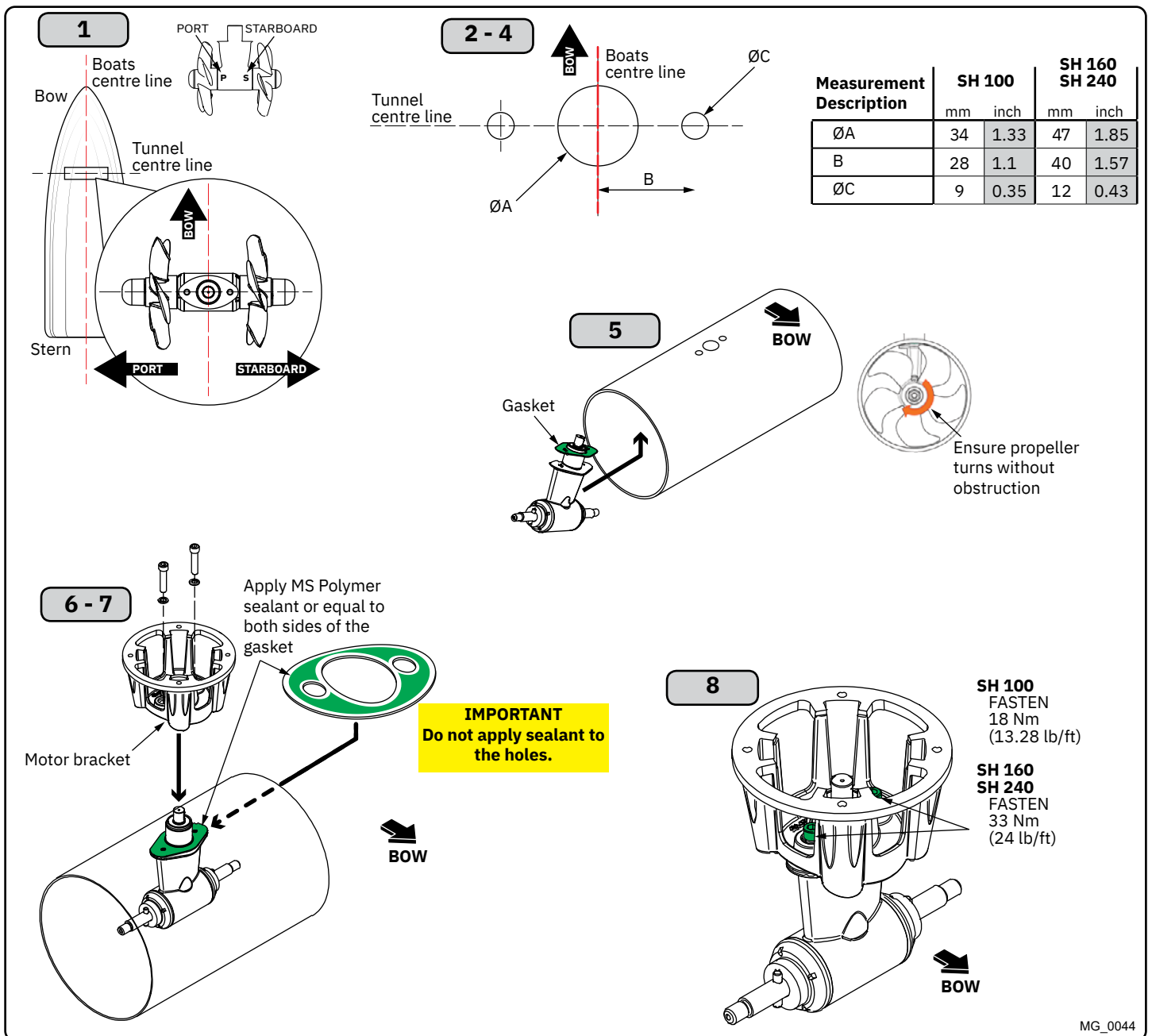

EN **Gear Leg & Motor Bracket Installation** MC_0001

! Please refer to the graphic for special considerations relating to your model !

1. Mark the tunnel centreline and the boat's centreline. **(NB: Install the gear leg and propeller as shown above for the thrust direction to correspond with the control panel. Position gear leg with the P-mark facing port and the S-mark facing starboard.)**
2. Use the gasket or template (recommended) to mark the hole centres and double-check the measurements. The centre hole MUST be placed using the boat centreline as shown above. **(NB: All holes must be in-line with the tunnels' centreline for correct installation, clearance between the propeller and the tunnel is minimal.)**
3. Smooth the surface of the tunnel. A rough surface will cause possible failure/movement of the gear leg. The motor bracket must rest steadily on the tunnel.
4. Drill the main centre hole followed by the two screw-holes.
5. Place the gear leg (without the propeller) with the gasket on inside the tunnel. Place the propeller on the gear leg to ensure it is centred and rotates freely with the same clearance from each blade to the tunnel wall. Place top motor bracket to measure the drive shaft has come through the motor bracket at the correct height. Remove the gear leg and propeller for final installation.
6. Apply appropriate sealant to both sides of the gasket and place on the gear leg. Place the gear leg in the tunnel (without the propeller).
7. Install the top motor bracket and gear leg gently together. Use appropriate sealant to ensure that no leakages occur. **(NB: See your sealant data sheet for the correct application process.)**
8. Fasten the gear leg and the motor bracket with the bolts provided. Fasten to torque as shown above.

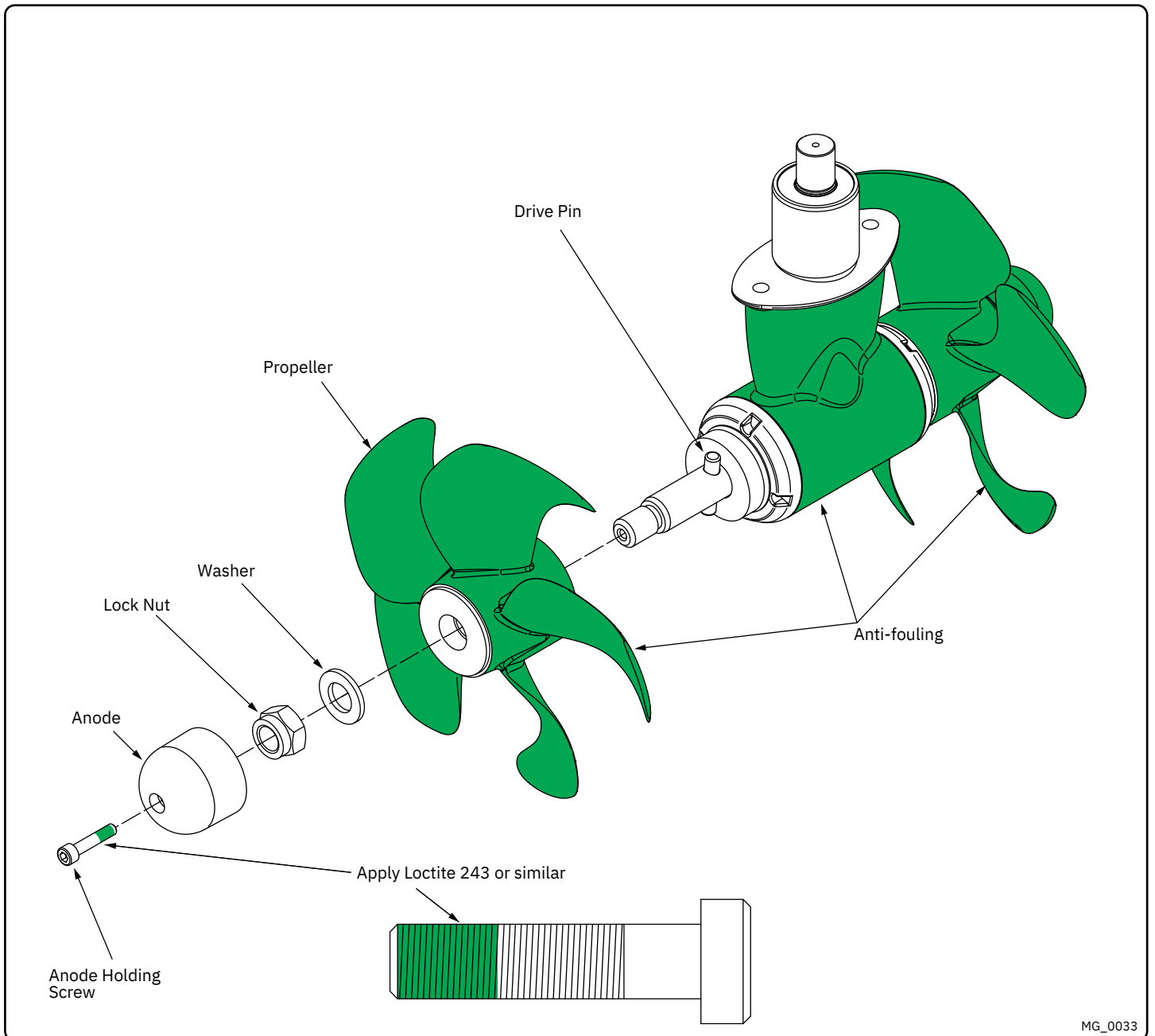

MG_0033

EN

Propeller Installation

MC_0018

! Please refer to the graphic for special considerations relating to your model !

1. Centre the drive pin and Insert the propeller onto the shaft spine. Rotate the propeller until the drive pin aligns with the internal slot in the propeller.
2. Insert the washer to the end of the shaft spline. Tighten with the propeller lock-nut.
3. Insert the anode to the end of the propeller and tighten the anode holding screw. Apply a thread glue (Loctite 243 or similar) to ensure that the anode holding screw does not unscrew itself from during the rotation of the propeller.
4. Apply anti-fouling to the gear leg and propeller. Do not apply anti-fouling to any rubber elements of the gear leg or anodes.

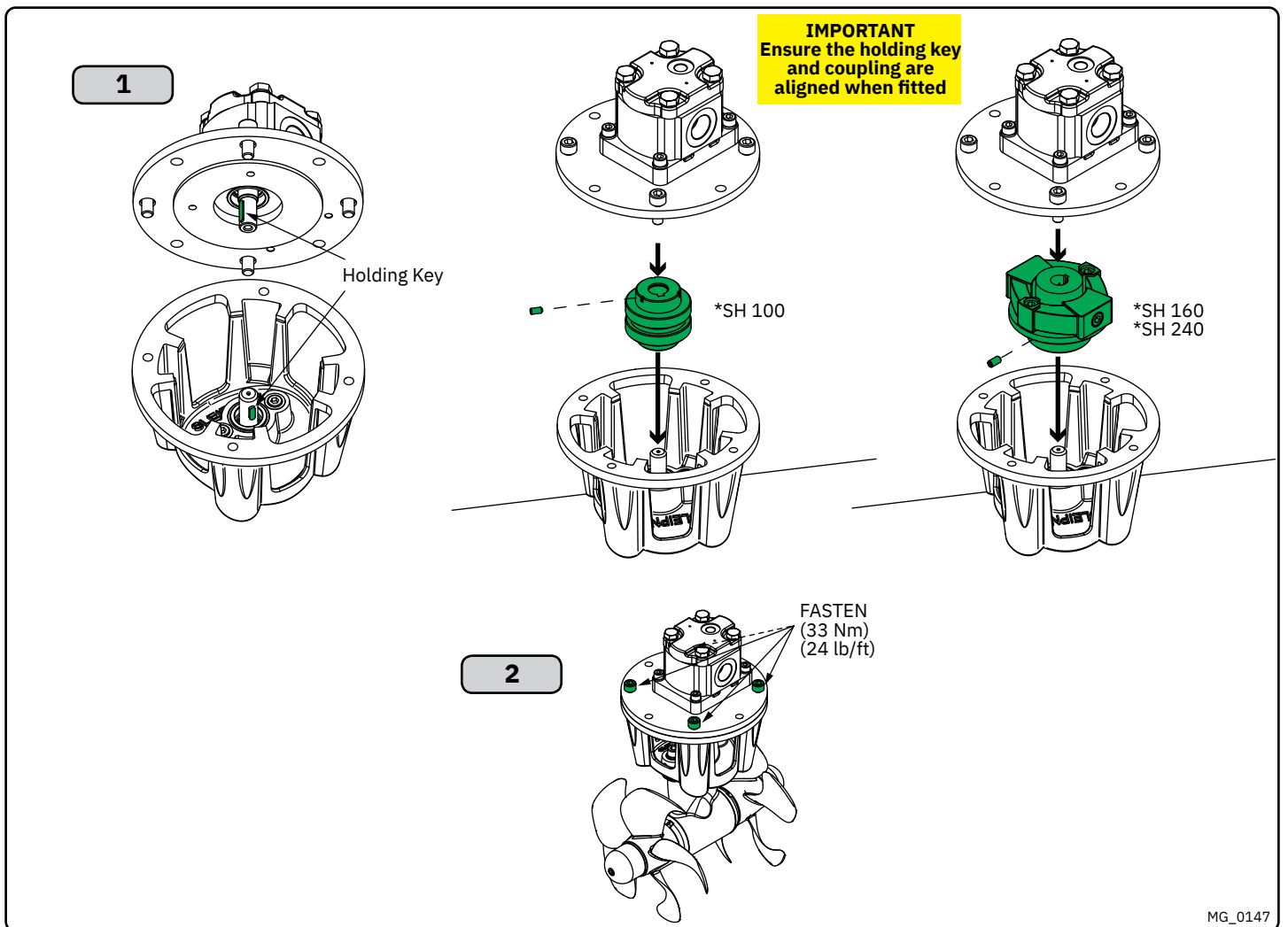

EN **Motor Installation** MC_0109

! Please refer to the graphic for special considerations relating to your model !

1. Install the motor onto the motor bracket ensuring the couplings are engaged together correctly. **(NB: The motor can be placed in all directions on the motor bracket. However, ensure the hose terminals are accessible for connection installation later.)**
2. Apply seawater resistant grease on the shafts before fitting the flexible coupling. Fasten the bolts holding the motor to the motor bracket with the above torque.
3. Check the drive shafts are engaged by rotating the propeller. **(NB: Rotating the propellers can be hard due to the gear reduction and the motor, however the propeller must be able to rotate via hand power.)**

IMPORTANT
The hydraulic motor must be covered to avoid dust from fabrication/ maintenance operation entering the motor hose pipes.

Example of the control wiring with S-link system for boats with one control position and one thruster.

Control Panel



You need:

- 2 x 6 1327 End terminators
- 3 x 6 1326 T-connectors
- 1 x 6 1328 Power spur
- 2 x 6 1320-xxM Backbone cables
- 2 x 6 1321-xxM Spur cables

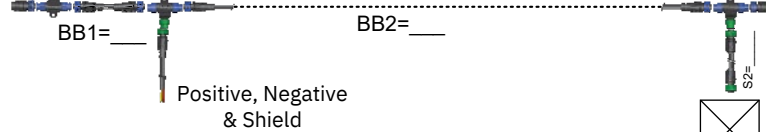

Thruster

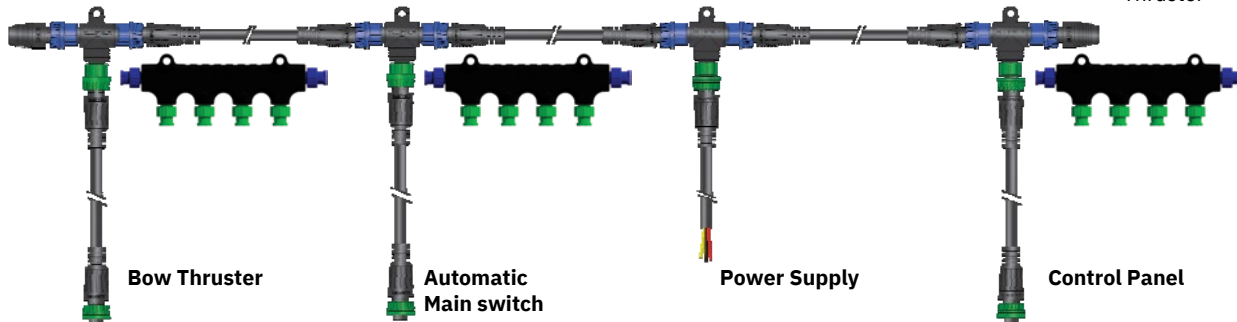

Bow Thruster

Automatic Main switch

Power Supply

Control Panel



BACKBONE Cable

Forms the main "loop" around the boat.



T- Connector

Must be one for each spur, including power cable



SPUR Cable

Must be used to connect all parts to the backbone cable (One for each component, no exceptions). Recommended to be as short as practically possible.



BACKBONE extender

Connects two BACKBONE cables to extend length.



POWER Cable

Must be one in each system, length 2.5m



END terminator

Must be one for each end of the BACKBONE "loop".



4-Port T Connector

The 4-port T-connector allows multiple spur cables to be connected. *(NB: Comes with two sealing caps to protect.)*

MG_0159

EN

S-link Planning & Precautions

MC_0120

S-link is a "CAN" based control system with full intelligent communication between all units in the system.

Main advantages include:

- Round, compact and waterproof plugs with unique keying and colour coding to avoid faulty hookup.
- An unlimited number of commands or information transfer on a single cable.
- Proprietary Sleipner commands but built 100% on NMEA 2000 standard.

Routing the Backbone:

Keep routing backbone spur cables to a minimum. Avoid routing the S-link cables close to equipment that might cause interference to the S-link signals such as radio transmitter equipment, antennas or high voltage cables. The backbone MUST be terminated at each end with the 6 1327 End Terminator.

Spur cables:

Spur cables can be left not terminated *(NB: Routing can be prepared for future additional equipment)*. Make sure to protect open connectors from water and moisture to avoid corrosion in the connectors.

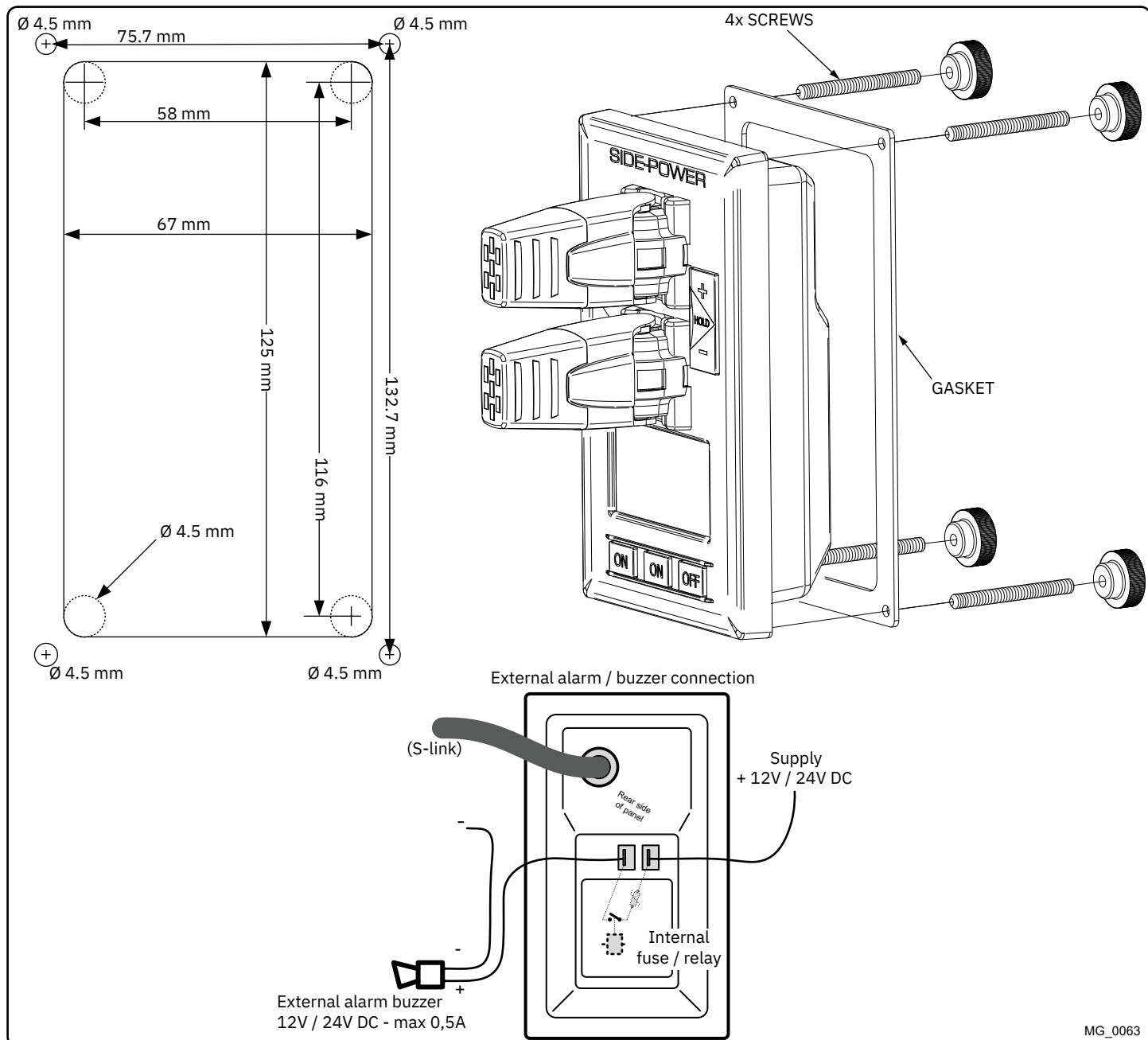

EN

Control Panel Installation

MC_0042

! Please refer to the graphic for special considerations relating to your model !

Find a suitable location for the control panel where it does not obstruct or is obstructed by other devices. Install the control panel on a flat surface where it is easy to use.

1. Use the supplied cut-out template to mark the area to remove on your control dash.
2. Cut out the area per template for the control panel. **(NB: If the front surface around your cut out is jagged or chipped, use a sealant to assist the gasket.)**
3. Place the gasket to the back face of the panel
4. Plug cables into the connectors at the rear of the control panel.
5. Insert the control panel in place and fasten screws.
6. Insert the control panels covering caps.

- Propeller is fastened correctly to the shaft.
- Propeller turns freely in tunnel.
- Lower-unit is filled with gear oil.
- Oil-drain screw is tightened and the copper seal is present.
- The anode holding screw is tightened well with thread glue.
- Anti-fouling have been applied to the gear house and propeller but NOT on the anode or the gear house lid where the propeller is fastened.
- Oil tank is fitted above the waterline as required and filled with gear oil.
- Correct drive direction as per control panel.
- The bolts holding the gear house and motor bracket together are tightened correctly.
- The bolts holding the motor to its bracket are tightened correctly.

The thruster has been installed as per the instructions in this manual and all points in checklist above have been controlled.

Signed:

Date:

Extra pre-delivery tests by installer / yard who does not use other quality control systems !

Thruster type:

Serial number:.....

Date of delivery:.....

Correct drive direction as per control panel:

The compartment for the thruster has been isolated from general bilge water and has no obvious or suspected risks for flooding:

.....
.....
.....

Other comments by installer:

.....

Find your local professional dealer from our certified worldwide network for expert service and support.

visit our website www.sleipnergroun.com/support

For additional supporting documentation, we advise you to visit our website www.sleipnergroun.com and find your Sleipner product.

1. Sleipner Motor AS (The "Warrantor") warrants that the equipment (parts, materials and embedded software of products) manufactured by the Warrantor is free from defects in workmanship and materials for the purpose for which the equipment is intended and under normal use and service (the "Warranty").
2. This Warranty is in effect for two years (Leisure Use) or one year (Commercial and other Non-leisure Use) from the date of purchase by the end user (for demonstration vessels, the dealer is deemed as end user).
3. This Warranty is transferable and covers the equipment for the specified warranty period.
4. The warranty does not apply to defects or damages caused by faulty installation or hook-up, abuse or misuse of the equipment including exposure to excessive heat, salt or fresh water spray, or water immersion except for equipment specifically designed as waterproof.
5. In case the equipment seems to be defective, the warranty holder (the "Claimant") must do the following to make a claim:
 - (a) Contact the dealer or service centre where the equipment was purchased and make the claim. Alternatively, the Claimant can make the claim to a dealer or service centre found at www.sleipnergroun.com. The Claimant must present a detailed written statement of the nature and circumstances of the defect, to the best of the Claimant's knowledge, including product identification and serial nbr., the date and place of purchase and the name and address of the installer. Proof of purchase date should be included with the claim, to verify that the warranty period has not expired;
 - (b) Make the equipment available for troubleshooting and repair, with direct and workable access, including dismantling of furnishings or similar, if any, either at the premises of the Warrantor or an authorised service representative approved by the Warrantor. Equipment can only be returned to the Warrantor or an authorised service representative for repair following a pre-approval by the Warrantor's Help Desk and if so, with the Return Authorisation Number visible postage/shipping prepaid and at the expense of the Claimant.
6. Examination and handling of the warranty claim:
 - (a) If upon the Warrantor's or authorised service Representative's examination, the defect is determined to result from defective material or workmanship in the warranty period, the equipment will be repaired or replaced at the Warrantor's option without charge, and returned to the Purchaser at the Warrantor's expense. If, on the other hand, the claim is determined to result from circumstances such as described in section 4 above or a result of wear and tear exceeding that for which the equipment is intended (e.g. commercial use of equipment intended for leisure use), the costs for the troubleshooting and repair shall be borne by the Claimant;
 - (b) No refund of the purchase price will be granted to the Claimant, unless the Warrantor is unable to remedy the defect after having a reasonable number of opportunities to do so. In the event that attempts to remedy the defect have failed, the Claimant may claim a refund of the purchase price, provided that the Claimant submits a statement in writing from a professional boating equipment supplier that the installation instructions of the Installation and Operation Manual have been complied with and that the defect remains.
7. Warranty service shall be performed only by the Warrantor, or an authorised service representative, and any attempt to remedy the defect by anyone else shall render this warranty void.
8. No other warranty is given beyond those described above, implied or otherwise, including any implied warranty of merchantability, fitness for a particular purpose other than the purpose for which the equipment is intended, and any other obligations on the part of the Warrantor or its employees and representatives.
9. There shall be no responsibility or liability whatsoever on the part of the Warrantor or its employees and representatives based on this Warranty for injury to any person or persons, or damage to property, loss of income or profit, or any other incidental, consequential or resulting damage or cost claimed to have been incurred through the use or sale of the equipment, including any possible failure or malfunction of the equipment or damages arising from collision with other vessels or objects.
10. This warranty gives you specific legal rights, and you may also have other rights which vary from country to country.

At Sleipner we continually invest to develop and offer the latest technology in marine advancements. To see the many unique designs we have patented visit our website www.sleipnergroun.com/patents

© Copyright Sleipner Motor AS, 2021

The information given in the document was correct at the time it was published.

However, Sleipner Motor AS can not accept liability for any inaccuracies or omissions it may contain. Continuous product improvement may change the product specifications without notice.

Therefore, Sleipner Motor AS can not accept liability for any possible differences between product and document.

Register your product and learn more at www.sleipnergroun.com



SLEIPNER AS

P.O. Box 519

N-1612 Fredrikstad

Norway

www.sleipnergroun.com

Made in Norway

