



PowerLED Dimming Control Reference Manual

- **ILIM80120**
Imtra PowerLED Dimmer
(See page 3)

- **PWM Control of PowerLED Lights
through a centralized lighting control
system**
(See page 6)



Overview

In order to provide control of our PowerLED lighting fixtures to support various lighting applications, Imtra offers a range of dimming control solutions.

Imtra's model ILIM80120 LED Dimmer Module provides dimming for all Imtra PowerLED Downlights and supports several functions including digital PWM output and four modes of analog input including 0-10V Sink, 0-10V Sink/Source, 4-20mA, 10K Ω -100K Ω Potentiometer.

Specifications

ILIM80120

Height	0.80" (20mm)
Width	2.66" (68mm)
Depth	2.08" (53mm)
Input Voltage Range	10-40VDC
Capacity	30 Fixtures*
Control Interface	N.O. Contacts
IP Rating	IP40

***Note:** Exceeding maximum number of fixtures can permanently damage dimmer module.

Imtra PowerLED Dimmer



The ILIM80120 PowerLED Dimmer Module is used to manually operate a circuit of PowerLED Lights with on/off and dimming control. Before making any connections, be sure all power in the circuit is turned off at the breaker. To install your PowerLED dimmer, connect the wires according to the following wiring schematic. Failure to follow the wiring schematic exactly as shown will result in failure & permanent damage to the dimmer.

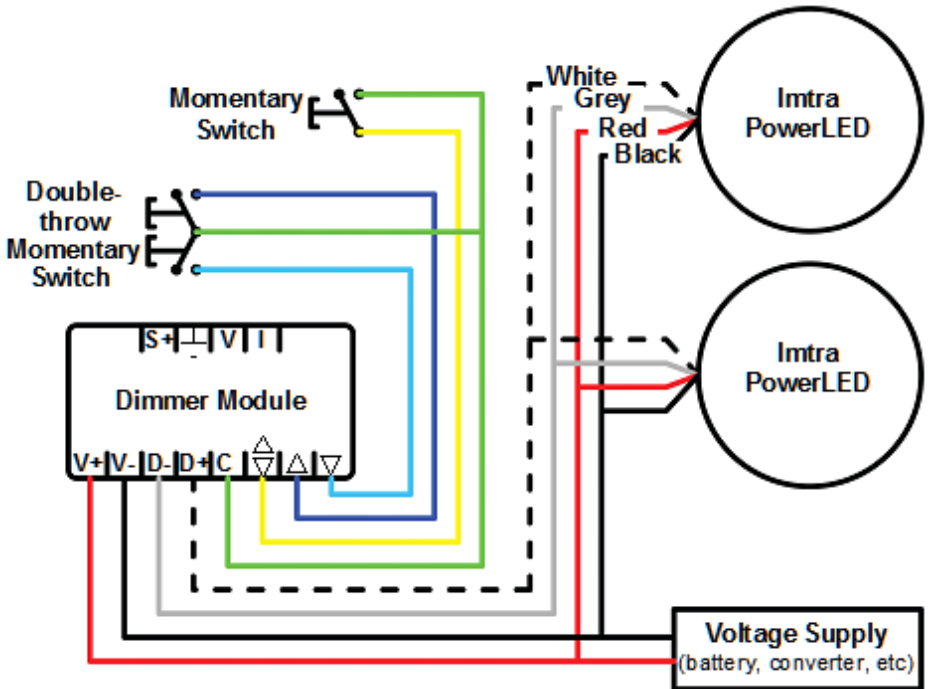

Operating your PowerLED Dimmer and Lights

- For single momentary pushbutton operation
 - Tap any one pushbutton to turn on or off.
 - Press and hold any one pushbutton to dim up or down.
- For double momentary pushbutton operation
 - Tap the button wired to the UP terminal to turn on
 - Tap the button wired to the DOWN terminal to turn off
 - Press and hold any one of the momentary pushbuttons to dim up or down.
- When the PowerLED Dimmer and Lights are set to off, a tap of the single or UP momentary pushbutton will always turn them on to the previous setting.
- When the PowerLED Dimmer and Lights are set to off, pressing and holding the single or UP momentary pushbutton will dim the lights up from 0%.

Power Up Default:

- When DC voltage to the PowerLED Dimmer and Lights is lost, the default setting when powered up again is always off.
- This default setting can be changed by following these steps:
 - Remove dimmer from the electrical circuit and disassemble the enclosure by removing the two screws on the back.
 - Locate the four DIP switches on the circuit board and slide switch 3 to the on position.
 - Reassemble the dimmer and wire according to the wiring schematic.

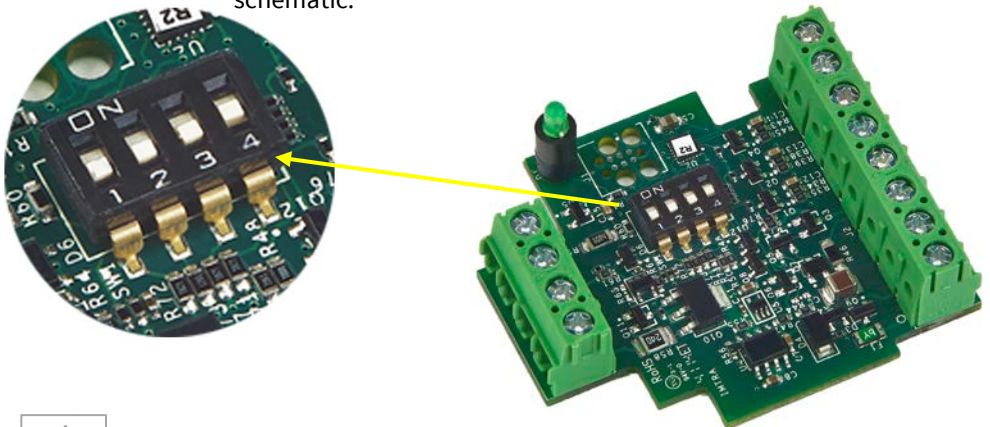

Imtra PowerLED Dimmer (0-10V)



The Imtra PowerLED Dimmer Module can be used for automated control of a circuit of PowerLED Lights. The PowerLED Dimmer Module can interface with any control system that can provide a 0-10VDC or 4-20mA Analog signal. To configure your dimmer for these controls, follow these steps:

- Disassemble the dimmer by removing the two screws on the back.
- Locate the four DIP switches on the circuit board and slide switch 2 to ON for 4-20mA signal or switch 1 and 2 to ON for 0-10V input.
- Reassemble the dimmer and connect per the following schematic. Before making any connections, be sure all power in the circuit is turned off at the breaker. Failure to follow the wiring schematic exactly as shown will result in failure & permanent damage to the dimmer.

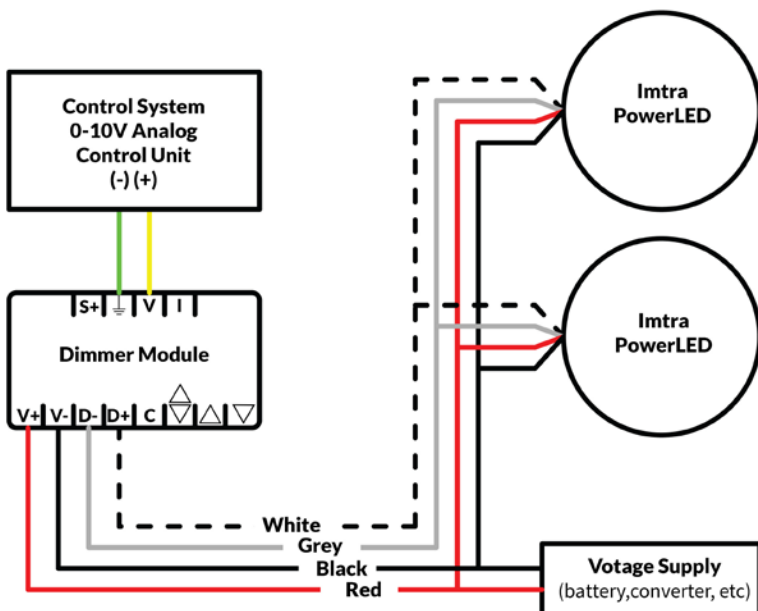

Note:

- For 0-10V signals, wire the signal positive to the V terminal.
- The PWM dimming level and 0-10V signal input are linearly related (0V,0%; 10V,100%)
- For 4-20mA signals, wire the signal to the I terminal
- The PWM dimming level and 4-20mA signal input are linearly related (4mA, 0%; 20mA, 100%)

PWM Control of PowerLED Lights

Imtra PowerLED Lights can also be controlled with a Pulse Width Modulating signal. Many centralized lighting automation systems use this type of control. To control your PowerLED using a PWM signal, the wiring and signal parameters should be configured according to details below.

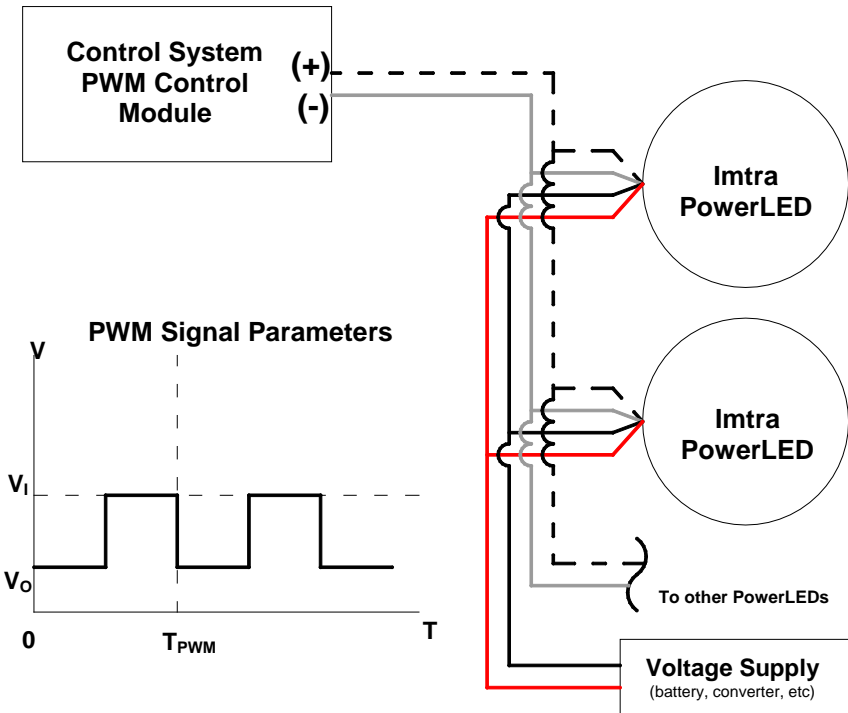

Note:

- $5.0\text{mS} < T_{PWM} < 8.33\text{mS}$ (PWM Frequency=120-200Hz)
- Dim signal voltage to be $0\text{VDC} < V_0 < 1.7\text{VDC}$ & $2.1\text{VDC} < V_1 < 30\text{VDC}$
- Current Sink $I=1\text{mA}$

Limited Warranty

Imtra warrants these dimming control products for 2 years from the date of purchase. If the dimmer module should cease to function within 2 years, return it to Imtra for repair or replacement.

This warranty does not apply to damage resulting from actions of the user such as misuse, improper wiring/installation, operation outside of specification, improper maintenance or repair, unauthorized modification, lightning strike or damage from a power surge.

Imtra specifically disclaims any implied warranties, merchantability or fitness for a specific purpose and will not be liable for any direct, indirect, incidental or consequential damages. Imtra's total liability is limited to repair or replacement of the product.

The warranty set forth above is inclusive and no other warranty, whether written or oral, is expressed or implied.

If it should become necessary to return a fixture for service during or beyond the warranty period, please refer to Imtra's standard Return Policy as detailed on Imtra's website (www.imtra.com) or call Imtra customer service (508)995-7000.

No returns are accepted without a Return Authorization (RA) number.



30 Samuel Barnet Boulevard, New Bedford, MA 02745
(508) 995-7000 • www.imtra.com