

## W50 Wiper Systems

Our wiper systems are engineered for reliability and performance - even in the worst conditions.

### W50 WIPER MOTOR

- 12VDC or 24VDC
- Choice of 3 bulkhead thicknesses
- 50Nm torque
- Drives arms & blades to 47.25"
- Two Speed Settings:
  - Low (30 sweeps/min)
  - High (47 sweeps/min)
- Dynamic park (left or right)
- Amp Draw:
  - 12V: <10A
  - 24V: <5A
- Recommended Fuse Size:
  - 12V: 40A Slow Blow
  - 24V: 20A Slow Blow

### W50 WIPER ARMS

- Available as pantograph
- Adjustable up to 47.25" (1200mm)
- Black anti-glare or electro-polished
- Standard dual spring on pantograph wiper arm
- 304 stainless steel
- Arms fold back for easy windshield cleaning
- Includes washing jet and tubing
- Accepts blades with 16mm width at connection

### W50 WIPER BLADES

- 304 stainless steel blades
- Available from 24" to 40"



### FEATURES

- Dual tapered drive shaft for secure motor/arm connection
- Stepless sweep angle adjustment
- Sweep angle adjustable from 45 - 110°
- Insulated ground for installation on metal, GRP and wooden boats
- CE approved; EMC protected

### BENEFITS

- Easy installation and wiring
- Choice of arm finish to fit surroundings perfectly
- Wide range of arms and blades to fit most any window
- Quality system at an affordable price
- 3 year warranty on motors & arms; 1 year for blades

**CONTROL OPTIONS**

Imtra offers a wide range of switching options for your wiper system. The choices range from simple rotary switches to full featured electronic control panels that allow for fingertip control of the operation of entire banks of wipers. Ask for more information or visit [www.imtra.com](http://www.imtra.com) to see all the wiper switching options.



**PRODUCT DETAILS**

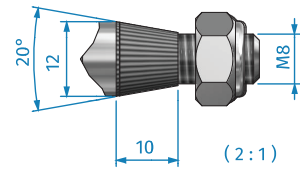
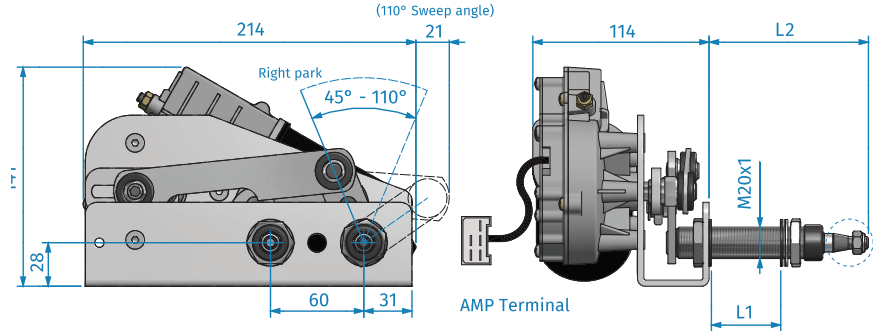

**INTEGRATED WASHING SYSTEMS**

Complete your wiper installation with a proper window washing system. Imtra has everything that you need to customize a washing or rinse down solution for your application.

We have it all - solenoids, plumbing fittings, high quality tubing, bulkhead connectors and manifolds for systems that plumb directly into the craft's pressure water system.



Or, choose a washing system that includes a dedicated fluid reservoir that allows for the use of anti-freeze or other additives for weather sensitive operation.



	MODEL	VOLTAGE	BULKHEAD THICKNESS	ITEM NO.	SWEEP ANGLE ADJUSTMENT
WIPER MOTORS	W50	12V	1.1" (28mm) 2.1" (53mm) 3.1" (78mm)	RC531013 RC531023 RC531033	45°-110° Slot stepless adjustable
		24V	1.1" (28mm) 2.1" (53mm) 3.1" (78mm)	RC531014 RC531024 RC531034	45°-110° Slot stepless adjustable
ARM LENGTH				ITEM NO.	ARM TYPE
WIPER ARMS	40 - 47" Adjustable Length, Electro-Polished SS w/Washing Jet (Can be cut down to 370mm, 14.5")			RC536347	Pantograph
	40 - 47" Adjustable Length, Black SS w/Washing Jet (Can be cut down to 370mm, 14.5")			RC538347	
BLADE TYPE			LENGTH	ITEM NO.	
WIPER BLADES	Standard Blades		24"	RC520824	
			28"	RC520828	
			30"	RC520830	
			32"	RC520832	
			33"	RC520833	
			34"	RC528034	
			35"	RC520835	
			38"	RC520838	
40"	RC520840				