

DYNAMIC TRIM CONTROL SYSTEM

# SERIES S

PRODUCT SPECIFICATION



**ZIPWAKE**

CHOOSE COMFORT. ENJOY PERFORMANCE.

**PRODUCT SPECIFICATION**  
DYNAMIC TRIM CONTROL SYSTEM SERIES S

Part number: 1010130  
Release: R3A, November 2023  
Language: English

# TABLE OF CONTENTS

<b>1</b>	<b>INTRODUCTION</b>	<b>4</b>
1.1	MOTION CONTROL FEATURES	
1.2	PRODUCTS AND PARTS OVERVIEW	
<b>2</b>	<b>KIT BOXES</b>	<b>8</b>
2.1	KIT BOX CONTENTS	
2.2	SPECIFICATIONS	
2.3	ORDERING DATA	
<b>3</b>	<b>CONTROL PANEL</b>	<b>10</b>
3.1	FEATURES	
3.2	SPECIFICATIONS	
3.3	INTERFACES	
3.4	DIMENSIONS	
3.5	ORDERING DATA	
<b>4</b>	<b>INTEGRATOR MODULE</b>	<b>12</b>
4.1	FEATURES	
4.2	SPECIFICATIONS	
4.3	INTERFACES	
4.4	DIMENSIONS	
4.5	ORDERING DATA	
<b>5</b>	<b>MINI CONTROLLER</b>	<b>14</b>
5.1	FEATURES	
5.2	INTERFACES	
5.3	SPECIFICATIONS	
5.4	DIMENSIONS	
5.5	ORDERING DATA	
<b>6</b>	<b>INTERCEPTORS</b>	<b>15</b>
6.1	FEATURES	
6.2	SPECIFICATIONS	
6.3	ORDERING DATA	
6.4	DIMENSIONS	
<b>7</b>	<b>DISTRIBUTION UNIT</b>	<b>24</b>
7.1	SPECIFICATIONS	
7.2	CONNECTORS	
7.3	DIMENSIONS	
7.4	ORDERING DATA	
<b>8</b>	<b>CABLES</b>	<b>26</b>
8.1	SPECIFICATIONS	
8.2	ORDERING DATA	
<b>9</b>	<b>CONTROL PANEL ALU FRAME</b>	<b>27</b>
9.1	SPECIFICATIONS	
9.2	ORDERING DATA	
<b>10</b>	<b>CONTROL PANEL COVER</b>	<b>27</b>
10.1	SPECIFICATIONS	
10.2	ORDERING DATA	
<b>11</b>	<b>CONTROL PANEL GIMBAL BRACKET</b>	<b>28</b>
11.1	SPECIFICATIONS	
11.2	DIMENSIONS	
11.3	ORDERING DATA	
<b>12</b>	<b>CABLE COVER</b>	<b>29</b>
12.1	SPECIFICATIONS	
12.2	DIMENSIONS	
12.3	ORDERING DATA	
<b>13</b>	<b>SERVO UNIT</b>	<b>30</b>
13.1	SPECIFICATIONS	
13.2	ORDERING DATA	
<b>14</b>	<b>INTERCEPTOR FRONTS</b>	<b>31</b>
14.1	SPECIFICATIONS	
14.2	DIMENSIONS	
14.3	ORDERING DATA	
<b>15</b>	<b>ADAPTOR PLATES</b>	<b>32</b>
15.1	SPECIFICATIONS	
15.2	DIMENSIONS	
15.3	ORDERING DATA	
<b>16</b>	<b>EXTERNAL GPS ANTENNA</b>	<b>34</b>
16.1	APPLICATION	
16.2	SPECIFICATIONS	
16.3	DIMENSIONS	
16.4	PIN OUT	
16.5	ORDERING DATA	
<b>17</b>	<b>WIRING DIAGRAMS</b>	<b>36</b>

# 1 INTRODUCTION

The Dynamic Trim Control System Series S incorporates a state-of-the-art family of durable, fast-acting Interceptors and unique 3D controls which provide the driver with unmatched, user-friendly, intuitive and precise control of running trim, heel or heading. The system is perfectly engineered to suit planing or semi-planing boats and can be configured for monohull or mutihull boats. The fully automatic system significantly enhances the boat's performance, fuel economy, comfort and safety.

## KEY FEATURES

### COMFORT AND SAFETY

Dynamically eliminates uncomfortable and dangerous boat pitch and roll.

### PERFORMANCE AND FUEL ECONOMY

Automatically minimizes wave resistance and saves fuel.

### INTUITIVE AND PRECISE CONTROL

Innovative 3D controls provide unmatched control of running trim, heel or heading.

### DURABLE AND EFFECTIVE

Patented series of durable fast-acting interceptors provide supreme lift force characteristics.

### COMPLETE AND COMPETITIVE

All-inclusive standardized modular design provides built-in quality, simple installation and easy expansion, while making the system affordable.

### INTEGRATION

The integrator module enables integration with complete system control on compatible multifunction displays (MFDs), making flexible installations and clean dashboard solutions possible. It is also possible to monitor system data on a wide range of plotters via the system's NMEA 2000® interface. The integrator module is compatible with all Zipwake system components.

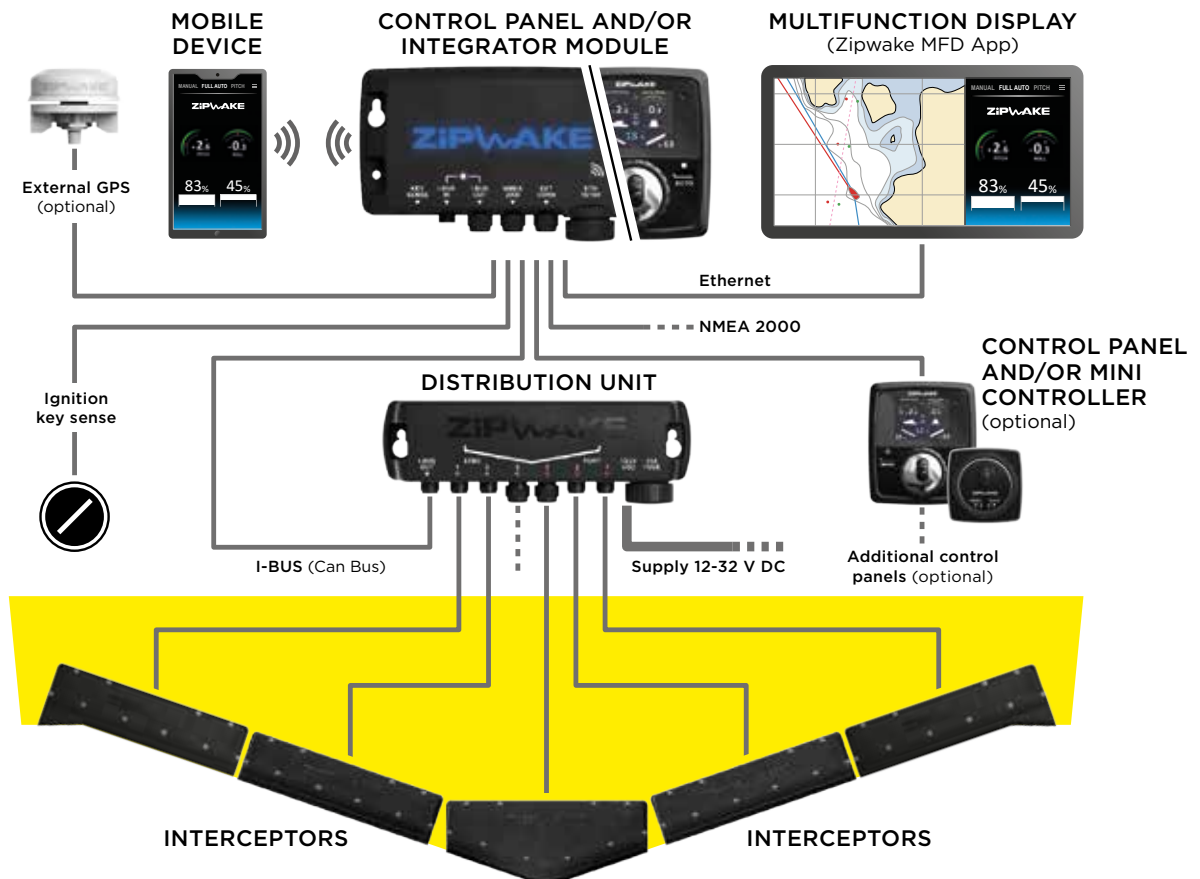

## 1.1 MOTION CONTROL FEATURES

Mode	Motion	Feature	Standard	Future
Automatic	Roll	Active roll control	•	
		Advanced turn recognition	•	
		Coordinated turn	•	
		Easy sensitivity control	•	
	Pitch	Curve-based pitch control	•	
		Pitch-offset control with quick save	•	
		Easy manipulation of pitch control curve	•	
		Basic pitch control curve from boat dimensions	•	
	Yaw	Auxiliary steering, controllable by other onboard system		•
	Manual	Roll	List control	•
Speed-progressive control wheel			•	
Pitch		Trim control	•	
		Speed-progressive control wheel	•	
Yaw		Steering control (calm sea or emergency steering)	•	
		Speed-progressive control wheel	•	

For details, refer to the Operator's Manual.

## 1.2 PRODUCTS AND PARTS OVERVIEW

Zipwake products and parts come as kit boxes, accessories or spare parts.

### KIT BOXES

			Kit Box Contents				
			Kit Box Part No.	2011145	2011146	2011147	2011148
Model	Part No.	Description	KB300-S	KB450-S	KB600-S	KB750-S	
<b>CP-S</b>	2011238	Control Panel S with Standard Cable 7 M	1	1	1	1	
<b>DU-S</b>	2011239	Distribution Unit S with Power Cable 4 M	1	1	1	1	
<b>IT300-S</b>	2011232	Interceptor 300 S with Cable 3 M & Cable Covers	2				
<b>IT450-S</b>	2011233	Interceptor 450 S with Cable 3 M & Cable Covers		2			
<b>IT600-S</b>	2011234	Interceptor 600 S with Cable 3 M & Cable Covers			2		
<b>IT750-S</b>	2011235	Interceptor 750 S with Cable 3 M & Cable Covers					2

			Kit Box Part No.	2011515	2011516	2011517	2011518
Model	Part No.	Description	KBI300-S	KBI450-S	KBI600-S	KBI750-S	
<b>IM</b>	2012241	Integrator Module	1	1	1	1	
<b>SC7-M12</b>	2011257	M12 Standard Cable 7 M	1	1	1	1	
<b>DU-S</b>	2011239	Distribution Unit S with Power Cable 4 M	1	1	1	1	
<b>IT300-S</b>	2011232	Interceptor 300 S with Cable 3 M & Cable Covers	2				
<b>IT450-S</b>	2011233	Interceptor 450 S with Cable 3 M & Cable Covers		2			
<b>IT600-S</b>	2011234	Interceptor 600 S with Cable 3 M & Cable Covers			2		
<b>IT750-S</b>	2011235	Interceptor 750 S with Cable 3 M & Cable Covers					2

			Kit Box Part No.	2011732	2011733	2011519	2011520
Model	Part No.	Description	KB300-S CHINE	KB450-S CHINE	KBI300-S CHINE	KBI450-S CHINE	
<b>CP-S</b>	2011238	Control Panel S with Standard Cable 7 M	1	1			
<b>IM</b>	2012241	Integrator Module			1	1	
<b>SC7-M12</b>	2011257	M12 Standard Cable 7 M			1	1	
<b>DU-S</b>	2011239	Distribution Unit S with Power Cable 4 M	1	1	1	1	
<b>IT300-S CHINE PORT</b>	2011702	Interceptor 300 S Chine Port side with Cable 3 M & Cable Covers	1		1		
<b>IT300-S CHINE STBD</b>	2011703	Interceptor 300 S Chine Starboard side with Cable 3 M & Cable Covers	1		1		
<b>IT450-S CHINE PORT</b>	2011704	Interceptor 450 S Chine Port side with Cable 3 M & Cable Covers		1		1	
<b>IT450-S CHINE STBD</b>	2011705	Interceptor 450 S Chine Starboard side with Cable 3 M & Cable Covers		1		1	

### ACCESSORIES AND SPARE PARTS

Model	Part No.	Description	Accessory	Spare Part
<b>IM</b>	2012241	Integrator Module	●	●
<b>MC</b>	2012401	Mini Controller with Standard Cable 3 M	●	●
<b>CP-S</b>	2011238	Control Panel S with Standard Cable 7 M	●	●
<b>CP ALU FRAME</b>	2011281	Control Panel Alu Frame	●	●
<b>DU-S</b>	2011239	Distribution Unit S with Power Cable 4 M	●	●
<b>CC-S</b>	2011071	Cable Cover S Kit	●	●
<b>GPU</b>	2011240	Global Positioning Unit with Cable 5 M & Mount Kit	●	●

Model	Part No.	Description	Accessory	Spare Part
<b>IT300-S</b>	2011232	Interceptor 300 S with Cable 3 M & Cable Covers	●	●
<b>IT450-S</b>	2011233	Interceptor 450 S with Cable 3 M & Cable Covers	●	●
<b>IT600-S</b>	2011234	Interceptor 600 S with Cable 3 M & Cable Covers	●	●
<b>IT750-S</b>	2011235	Interceptor 750 S with Cable 3 M & Cable Covers	●	●
<b>IT300-S CHINE PORT</b>	2011702	Interceptor 300 S Chine Port side with Cable 3 M & Cable Covers	●	●
<b>IT300-S CHINE STBD</b>	2011703	Interceptor 300 S Chine Starboard side with Cable 3 M & Cable Covers	●	●
<b>IT450-S CHINE PORT</b>	2011704	Interceptor 450 S Chine Port side with Cable 3 M & Cable Covers	●	●
<b>IT450-S CHINE STBD</b>	2011705	Interceptor 450 S Chine Starboard side with Cable 3 M & Cable Covers	●	●
<b>IT300-S INTER</b>	2011701	Interceptor 300 S Intermediate with Cable 3 M & Cable Covers	●	●
<b>IT450-S V13</b>	2011482	Interceptor 450 S V13 with Cable 3 M & Cable Covers	●	●
<b>IT450-S V16</b>	2011483	Interceptor 450 S V16 with Cable 3 M & Cable Covers	●	●
<b>IT450-S V19</b>	2011484	Interceptor 450 S V19 with Cable 3 M & Cable Covers	●	●
<b>IT450-S V22</b>	2011485	Interceptor 450 S V22 with Cable 3 M & Cable Covers	●	●
<b>EC1.5-M12</b>	2011258	M12 Extension Cable 1.5 M	●	●
<b>EC3-M12</b>	2011259	M12 Extension Cable 3 M	●	●
<b>EC5-M12</b>	2011260	M12 Extension Cable 5 M	●	●
<b>EC10-M12</b>	2011261	M12 Extension Cable 10 M	●	●
<b>EC15-M12</b>	2012038	M12 Extension Cable 15 M	●	●
<b>EC20-M12</b>	2012039	M12 Extension Cable 20 M	●	●
<b>SC3-M12</b>	2012408	M12 Standard Cable 3 M	●	●
<b>SC7-M12</b>	2011257	M12 Standard Cable 7 M	●	●
<b>SC15-M12</b>	2012037	M12 Standard Cable 15 M	●	●
<b>CP COVER</b>	2011381	Control Panel Cover, White	●	●
	2011382	Control Panel Cover, Light gray	●	●
	2011383	Control Panel Cover, Mid gray	●	●
	2011384	Control Panel Cover, Dark gray	●	●
	2011385	Control Panel Cover, Black	●	●
<b>GB</b>	2011622	Gimbal Bracket for Control Panel	●	●
<b>AP300-S</b>	2011585	Adaptor Plate 300 S Kit	●	●
<b>AP450-S</b>	2011586	Adaptor Plate 450 S Kit	●	●
<b>SU-S</b>	2011230	Servo Unit S with Cable 3 M		●
<b>IT300-S FRONT</b>	2011252	Interceptor 300 S Front		●
<b>IT450-S FRONT</b>	2011253	Interceptor 450 S Front		●
<b>IT600-S FRONT</b>	2011254	Interceptor 600 S Front		●
<b>IT750-S FRONT</b>	2011255	Interceptor 750 S Front		●
<b>IT300-S CHINE PORT FRONT</b>	2011742	Interceptor 300 S Chine Port side Front		●
<b>IT300-S CHINE STBD FRONT</b>	2011743	Interceptor 300 S Chine Starboard side Front		●
<b>IT450-S CHINE PORT FRONT</b>	2011744	Interceptor 450 S Chine Port side Front		●
<b>IT450-S CHINE STBD FRONT</b>	2011745	Interceptor 450 S Chine Starboard side Front		●
<b>IT300-S INTER FRONT</b>	2011741	Interceptor 300 S Intermediate Front		●
<b>IT450-S V13 FRONT</b>	2011492	Interceptor 450 S V13 Front		●
<b>IT450-S V16 FRONT</b>	2011493	Interceptor 450 S V16 Front		●
<b>IT450-S V19 FRONT</b>	2011494	Interceptor 450 S V19 Front		●
<b>IT450-S V22 FRONT</b>	2011495	Interceptor 450 S V22 Front		●

## 2 KIT BOXES

Kit boxes include all the parts needed to install a Dynamic Trim Control System with one pair of fast-acting straight or chine interceptors. There are six standard kit boxes, each with a stylish, user-friendly, intuitive control panel, and six kit boxes for integration with a module for hard-wired system integration and wireless communication.



### 2.1 KIT BOX CONTENTS

Standard kit box includes:

**INTERCEPTOR**

**2 x Interceptors**  
with Cable 3 m & Cable Cover

**DISTRIBUTION UNIT**

**1 x Distribution Unit**  
with Power Cable 4 m

- + Operator's Manual
- + Warranty Card
- + Installation Guide
- + Drill Templates
- + Mounting Screws
- + Operator's Quick Guide
- + Startup Checklist

**CONTROL PANEL**

**1 x Control Panel**  
with Standard Cable 7 m

Kit box for integration includes:

**INTERCEPTOR**

**2 x Interceptors**  
with Cable 3 m & Cable Cover

**DISTRIBUTION UNIT**

**1 x Distribution Unit**  
with Power Cable 4 m

- + Operator's Manual
- + Warranty Card
- + Installation Guide
- + Drill Templates
- + Mounting Screws
- + Operator's Quick Guide
- + Startup Checklist

**INTEGRATOR MODULE**

**1 x Integrator Module**

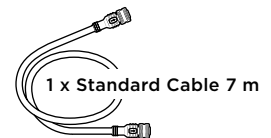

Any base installation can be expanded with up to two extra pairs of Series S interceptors, thus allowing a total of six interceptors without any need for additional connectors or power supply.



## 2.2 SPECIFICATIONS

Standard kit box:

Model	KB300-S	KB450-S	KB600-S	KB750-S	KB300-S CHINE	KB450-S CHINE	
<b>Width</b>	680 (26.8)	680 (26.8)	980 (38.6)	980 (38.6)	680 (26.8)	680 (26.8)	mm (in)
<b>Depth</b>	156 (6.1)	156 (6.1)	156 (6.1)	156 (6.1)	156 (6.1)	156 (6.1)	mm (in)
<b>Height</b>	274 (10.8)	274 (10.8)	274 (10.8)	274 (10.8)	274 (10.8)	274 (10.8)	mm (in)
<b>Weight</b>	6.9 (15.2)	8.4 (18.5)	10.4 (22.9)	11.5 (25.4)	7.1 (15.7)	8.6 (19)	kg (lbs)

Kit box for integration:

Model	KBI300-S	KBI450-S	KBI600-S	KBI750-S	KBI300-S CHINE	KBI450-S CHINE	
<b>Width</b>	680 (26.8)	680 (26.8)	980 (38.6)	980 (38.6)	680 (26.8)	680 (26.8)	mm (in)
<b>Depth</b>	156 (6.1)	156 (6.1)	156 (6.1)	156 (6.1)	156 (6.1)	156 (6.1)	mm (in)
<b>Height</b>	274 (10.8)	274 (10.8)	274 (10.8)	274 (10.8)	274 (10.8)	274 (10.8)	mm (in)
<b>Weight</b>	7 (15.4)	8.5 (18.7)	10.5 (23.1)	11.6 (25.6)	7.2 (15.9)	8.7 (19.1)	kg (lbs)

See section 1.2 for details of the contents of each kit box.

## 2.3 ORDERING DATA

Standard kit box:

Model	KB300-S	KB450-S	KB600-S	KB750-S	KB300-S CHINE	KB450-S CHINE	
<b>Part No.</b>	2011145	2011146	2011147	2011148	2011732	2011733	

Kit box for integration:

Model	KBI300-S	KBI450-S	KBI600-S	KBI750-S	KBI300-S CHINE	KBI450-S CHINE	
<b>Part No.</b>	2011515	2011516	2011517	2011518	2011519	2011520	

### 3 CONTROL PANEL

Zipwake's stylish control panel is carefully designed to be user-friendly and intuitive to allow the driver to focus on the right thing – enjoying the boat ride!

The panel's two unique control wheels provide easy, quick and intuitive manual control of running trim, heel or heading. However, the system normally operates in automatic control mode, which is enabled by a single press on the AUTO button. In this mode, the built-in high-frequency GPS, 3D gyro sensors and robust motion controller automatically ensure dynamic elimination of uncomfortable and dangerous boat pitch and roll.

The system provides continuous feedback of boat speed, pitch and roll angle, as well as the interceptors' positions, on a 2.4" sunlight-readable wide viewing color display.



The panel's waterproof design withstands harsh marine conditions in open boats or on a flybridge. The sockets for connecting peripherals are located on the rear of the panel. In addition to connectors for the system's distribution unit and multiple control panels, external GPS and NMEA2000 equipment can be connected. The system can also be connected to the ignition key for automatic system power-on. A waterproof cap conceals the USB interface that allows for future software upgrades and ensures that the Zipwake Dynamic Trim Control System is future-proof.

#### 3.1 FEATURES



- Fully automatic
  - Dynamic pitch and roll control
  - Steering and turn enhancement
- Built-in GPS and motion sensors
- Unique and intuitive 3D controls
- Sunlight readable color display
- Instant state user feedback
- Auto power on/off via ignition key sense
- Full range of electrical interfaces
- Waterproof
- Auto dimming / night mode
- Upgradable via USB stick
- Supports up to 3 additional control panels in the system
- Surface, flush or gimbal bracket mount
- Manages installation configurations from 1 up to 6 interceptors
- Auto cleaning
  - Selectable periodic cleaning cycle
  - Prevents fouling inside the interceptor
- Monitored and/or controlled from external devices, e.g. multifunction displays or plotters via its NMEA 2000 interface

### 3.2 SPECIFICATIONS

<b>Model</b>	CP-S
<b>Display</b>	2.4" IPS color TFT LCD, 320 x 240 pixels, double-sided, anti-reflection coated window
<b>Internal sensors</b>	5 Hz GPS, 3D Gyro, 3D Accelerometer, Ambient light
<b>Supply voltage</b>	12 - 32 V DC
<b>Power consumption</b>	10 W max
<b>Operating temperature</b>	-20° to +80°C (-4° to +176°F)
<b>Storage temperature</b>	-40° to +90°C (-40° to +194°F)
<b>Waterproof rating</b>	IP67 / IP64 (front / back)
<b>Compass safe distance</b>	0.5 m (1.7 ft)
<b>Compliance</b>	CE, FCC
<b>Weight</b>	0.22 kg (0.49 lbs)
<b>Mounting</b>	Surface, flush or gimbal bracket mount

### 3.3 INTERFACES

- I-BUS IN (CAN bus)
- I-BUS OUT (CAN bus)
- NMEA 2000
- Key sense
- USB device port (Type A)
- USB host port (Type B)
- External GPS (NMEA 0183 / RS232 auto baud-rate sensing)



### 3.4 DIMENSIONS

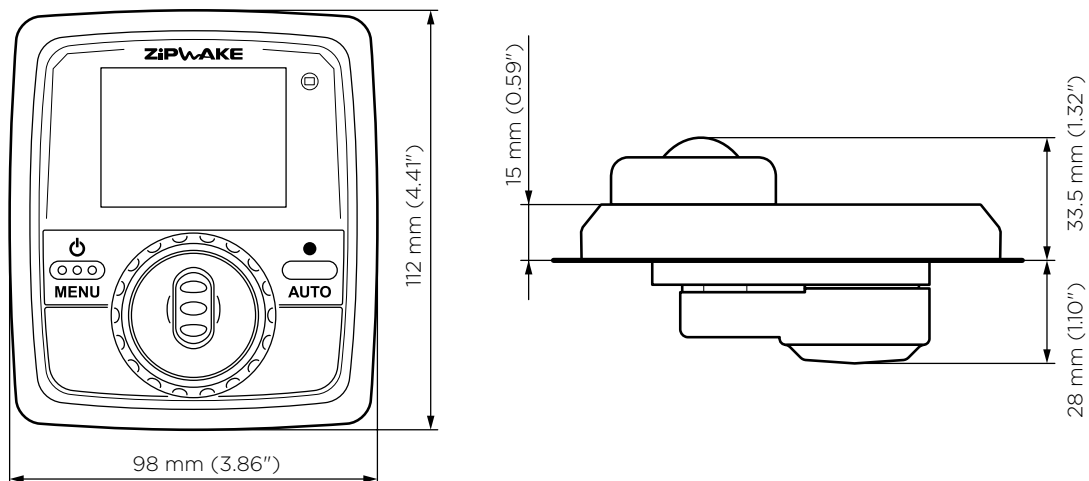

### 3.5 ORDERING DATA

<b>Model</b>	CP-S
<b>Part No.</b>	2011238 with Standard Cable 7 m

- Included in kit boxes
- Available as an accessory
- Available as a spare part

## 4 INTEGRATOR MODULE

The Zipwake integrator module enables total integration and clean dashboard solutions by connecting the Zipwake system to multifunction displays (MFDs) and/or smart devices. The embedded Zipwake user interface provides intuitive, easy control without the need for a separate control panel, although any Zipwake system will allow up to 3 additional control panels and/or mini controllers for anyone wanting both touch buttons and Zipwake's unique control wheels for ultimate manual control.



The integrator module supports connections to a wide range of MFD brands/models via an ethernet interface. Its wireless interface enables connection to smartphones and tablets by means of Zipwake's app for wireless views, control, configuration and software updates. The integrator also includes a CAN interface for further external system integration.

The integrator module has built-in motion sensors that also use GPS data acquired from either an NMEA 2000 connected network, an external GPS antenna, an extra control panel or a mini controller to ensure precise and dynamic control of the boat's pitch and roll. The module can be oriented in any direction and its rugged, waterproof design allows for flexible installation e.g. behind the helm/dash, on the flybridge or in the engine room. It comes with a special ethernet connector collar that makes sealing standard ethernet cables easy.

The integrator module is compatible with all Zipwake system components and is available as an accessory, a spare part or included in kit boxes for integration (refer to section 1.2).

### 4.1 FEATURES

- Fully automatic
  - Dynamic pitch and roll control
  - Steering and turn enhancement
- Motion sensors and magnetic compass
- Instant user feedback
- Auto power on/off via ignition key sense
- Waterproof design
  - Standard ethernet cable sealed by waterproof ethernet connector collar
- RGB LED status indicators for each interface
- Wireless upgradable via smartphones/tablets
- Supports up to three additional control panels and/or mini controllers in the system
- Compatible with all Zipwake system components
- Manages installation configurations from 1 to 6 Series E dual-servo interceptors or any mix with single-servo interceptors

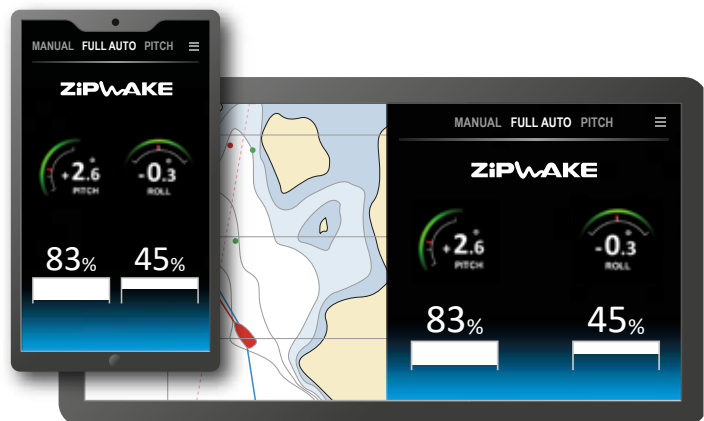

- Allows configuration of interceptor pair function
- Auto cleaning
  - Selectable periodic cleaning cycle
  - Prevents fouling inside the interceptor
- Monitored and/or controlled from external devices
  - Multifunction displays (MFDs) via ethernet
  - Smartphones/tables via wireless interface
  - Plotters via NMEA 2000 interface

## 4.2 SPECIFICATIONS

<b>Model</b>	IM
<b>Indicators</b>	RGB LEDs for each communication interface (x4) RGB backlit logo
<b>Internal sensors</b>	3D Gyro, 3D Accelerometer, Compass
<b>Supply voltage</b>	12 - 32 V DC
<b>Power consumption</b>	4 W max
<b>Operating temperature</b>	-20° to +60°C (-4° to +140°F)
<b>Storage temperature</b>	-40° to +90°C (-40° to +194°F)
<b>Waterproof rating</b>	IP67
<b>Compass safe distance</b>	0.5 m (1.7 ft)
<b>Compliance</b>	CE, FCC, SAE J1171 Ignition Protected
<b>Weight</b>	0.35 kg (0.77 lbs)

## 4.3 INTERFACES

- I-BUS IN (CAN bus)
- I-BUS OUT (CAN bus)
- NMEA 2000
- Key sense
- External connection
  - GPS (NMEA 0183 / RS232)
  - CAN (J1939)
- Ethernet (10/100G)
- Wi-Fi / Bluetooth

## 4.4 DIMENSIONS

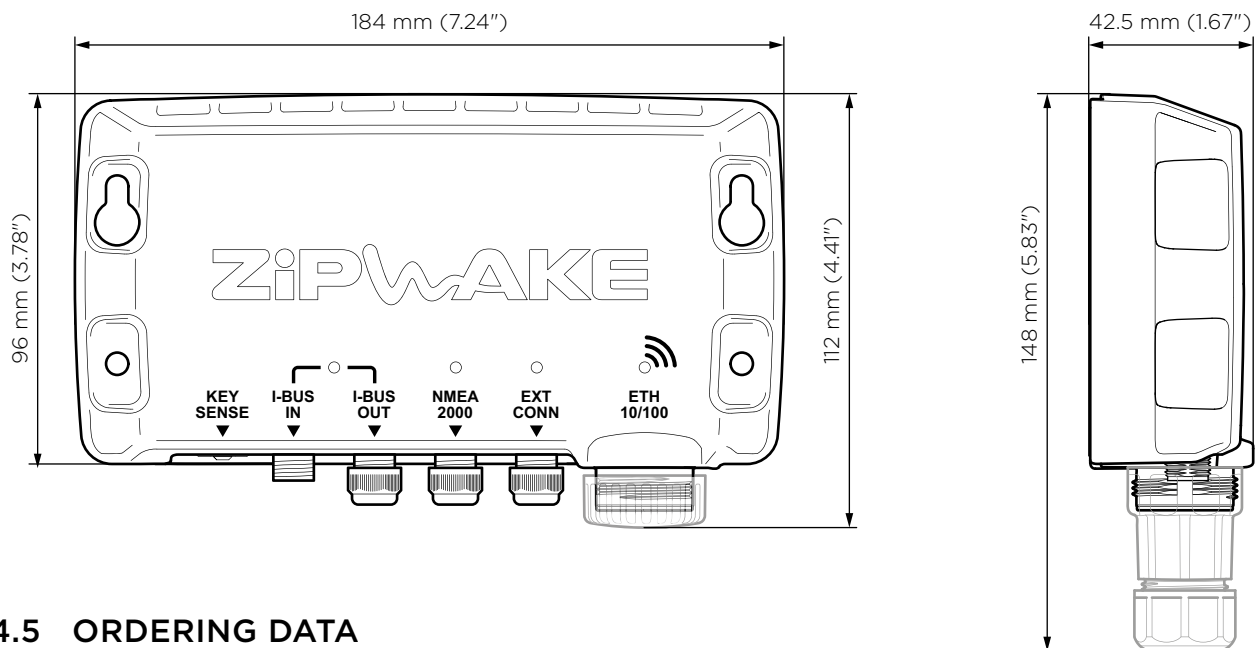

## 4.5 ORDERING DATA

<b>Model</b>	IM
<b>Part No.</b>	2012241

- Included in kit boxes for integration
- Available as an accessory
- Available as a spare part

## 5 MINI CONTROLLER

The Zipwake mini controller is the perfect complement for any Zipwake system with integrator module and MFDs. The small and intuitive mini controller provides easy manual control of running trim, heel or heading as well as system settings the same way as the well proven control panel.

The mini controller is designed to withstand harsh marine conditions in open boats or on a flybridge and can be mounted in any position suited for the helmsman. The mini controller can be connected to the integrator module and/or a control panel as well as the ignition key for automatic system power-on.



### 5.1 FEATURES

- Unique and intuitive 3D controls
- Auto power on/off via ignition key sense
- Built-in GPS
- Surface or flush mount

### 5.2 INTERFACES

- I-BUS IN (CAN bus)
- I-BUS OUT (CAN bus)
- Key sense

### 5.3 SPECIFICATIONS

<b>Model</b>	MC
<b>Indicators</b>	RGB LEDs
<b>Internal sensors</b>	18 Hz GPS
<b>Supply voltage</b>	12 - 32 V DC
<b>Power consumption</b>	2 W max
<b>Operating temperature</b>	-20° to +80°C (-4° to +176°F)
<b>Storage temperature</b>	-40° to +90°C (-40° to +194°F)
<b>Waterproof rating</b>	IP67
<b>Compass safe distance</b>	0.5 m (1.7 ft)
<b>Compliance</b>	CE, FCC
<b>Weight</b>	0.10 kg (0.22 lbs)

### 5.4 DIMENSIONS

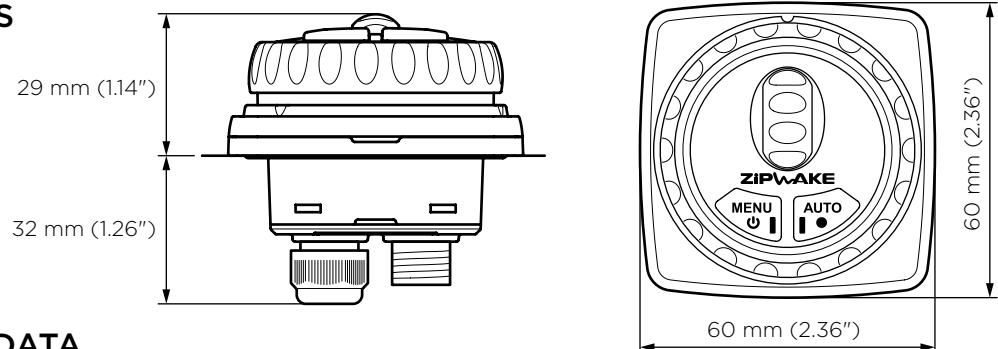

### 5.5 ORDERING DATA

<b>Model</b>	MC
<b>Part No.</b>	2012401 with Standard Cable 3 m

- Available as an accessory
- Available as a spare part

## 6 INTERCEPTORS

Series S is a product family that includes four straight, four V-shaped, four chine and one intermediate interceptor. This first-ever modular design made for mass production makes the interceptors durable, affordable and perfectly adapted to any planing or semi-planing boat between 6 m and 15 m (20-50 ft).

All components have been meticulously engineered to withstand impact and avoid water ingress, minimizing the risk of costly maintenance and downtime. Interceptor or blade actuation takes place by way of a calibration-free submersible electric servo in the interceptor unit. Its natural water cooling provides excellent working conditions for the brushless DC servo motor, which run on 12-32 volts. The blade stroke takes 1.5 seconds, outperforming conventional trim tabs by at least a factor of 5.

Installation is made easy with an integral mounting plate and the option of a concealed or above-waterline, self-sealing, thru-hull cable fitting. The preferred mounting option is achieved by simply routing the servo cable, as shown below. Each interceptor comes with the thru-hull cable fitting, cable covers and a practical drill template.

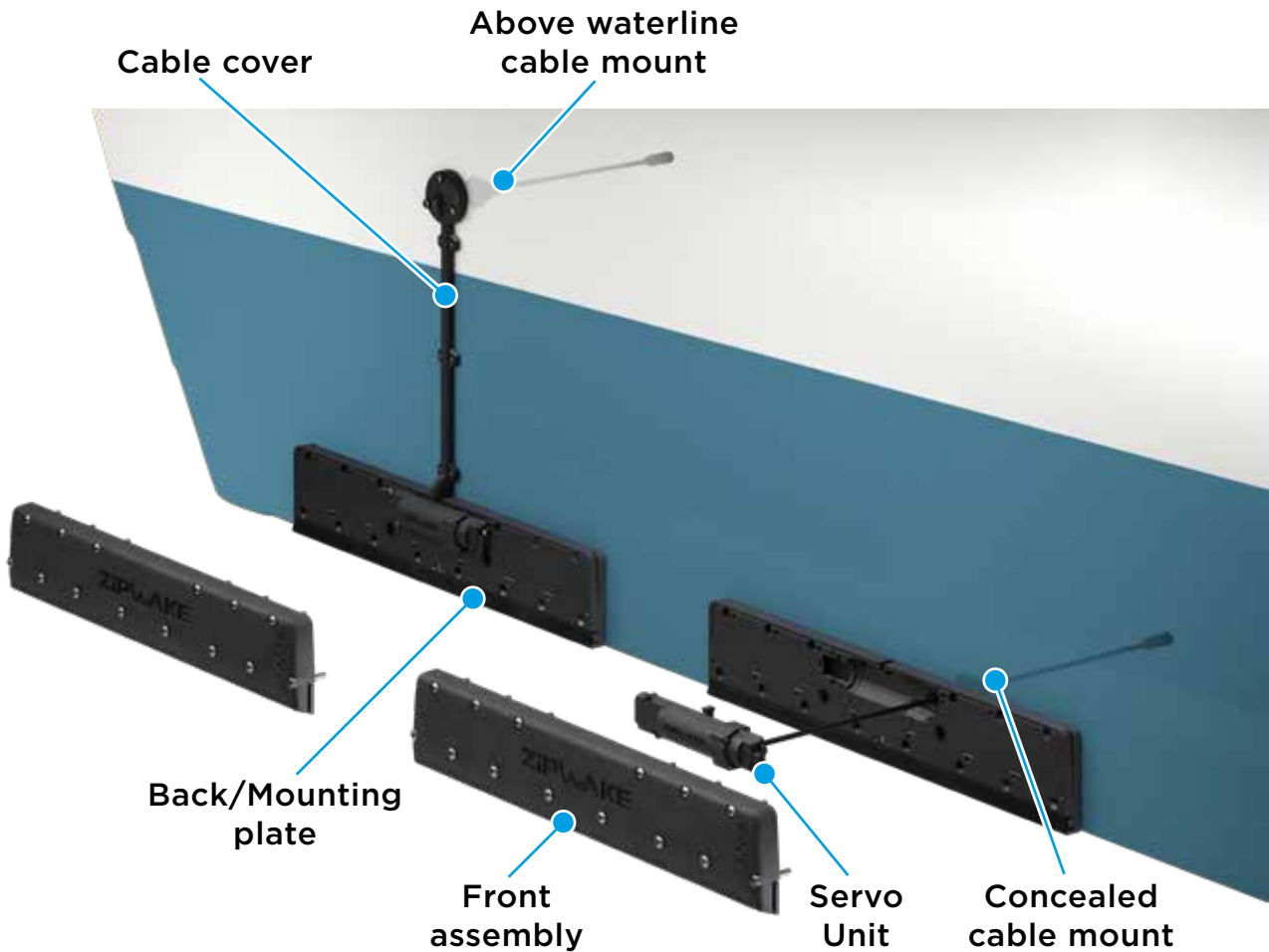



For best effect, different size interceptors can be combined to span as much of the transom edge as possible. A full beam is always the optimal arrangement from a lift-to-drag ratio point of view.

Combine any interceptors to get the perfect system for multihull boats e.g. power catamarans.

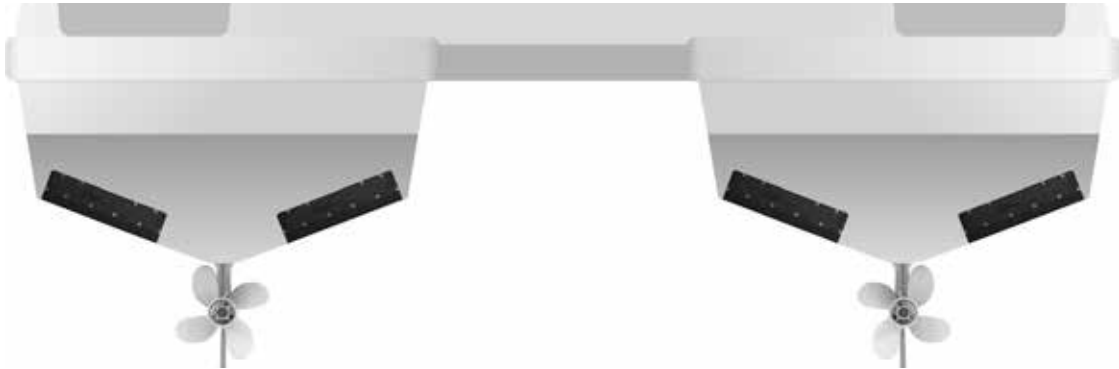

### V-shaped interceptors for centerline mounting

V-shaped interceptors for centerline mounting are perfect for filling the gap between twin outboards or sterndrives, as well as dual propeller tunnels.



The four V-shaped models cover deadrise angles effectively between 11 to 24 degrees. Centerline mounted interceptors can be included in new installations, or retro-fitted to already installed systems.

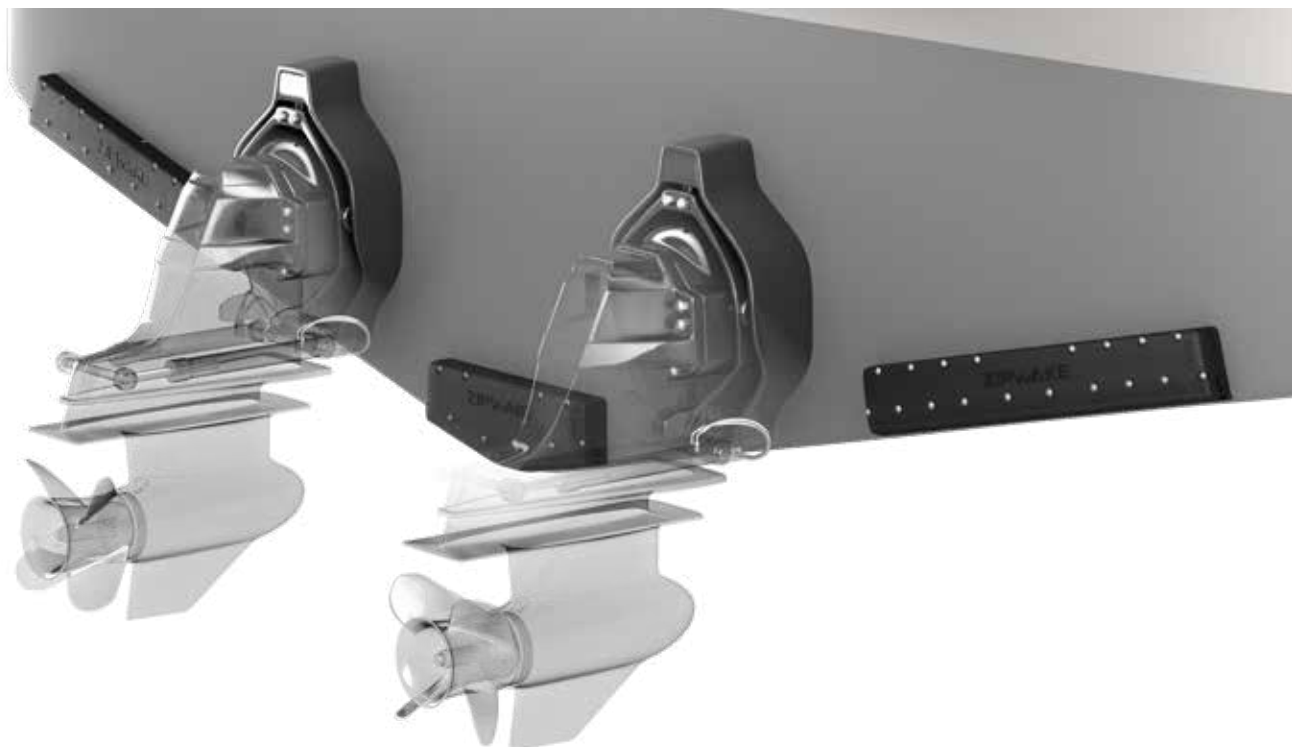



## Chine interceptors for maximum lift

Chine interceptors provide a unique means of maximizing pitch and roll motion control by utilizing the furthest outboard surfaces of the hull bottom for lift generation.



As a rule, the lift effect of a chine interceptor matches the lift of a straight interceptor one size larger mounted inboard of the chine, making them the go-to choice when selecting interceptors. Chine interceptors are particularly useful when transom space is limited abeam of outboards or sterndrives.

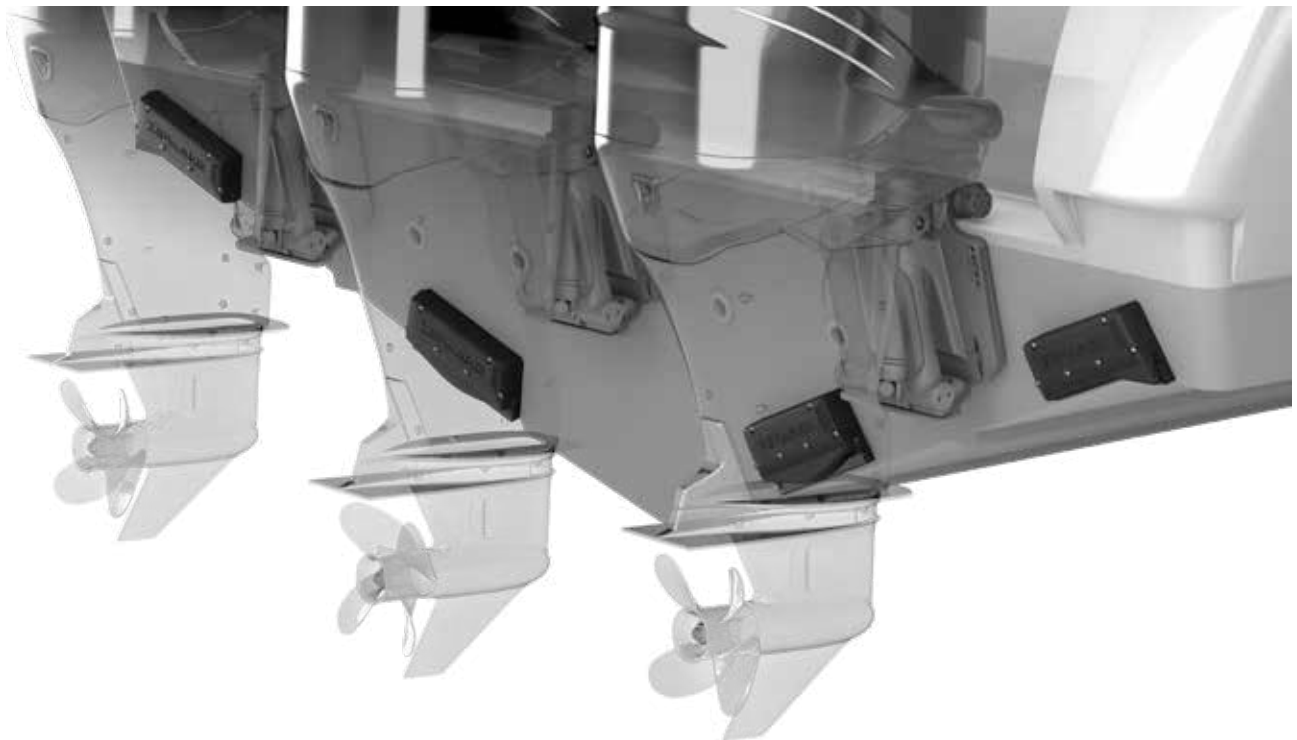

## Intermediate interceptor for installing close to propellers

When space between multiple outboards or sterndrives is tight, an intermediate interceptor offers a viable alternative for additional pitch and roll motion control not possible with a straight interceptor without degrading propeller performance.



Thanks to their special blade shape, intermediate interceptors generate a narrower trail, thus mitigating propeller inflow disturbance and even allowing installation between outboards mounted at their minimum offset.

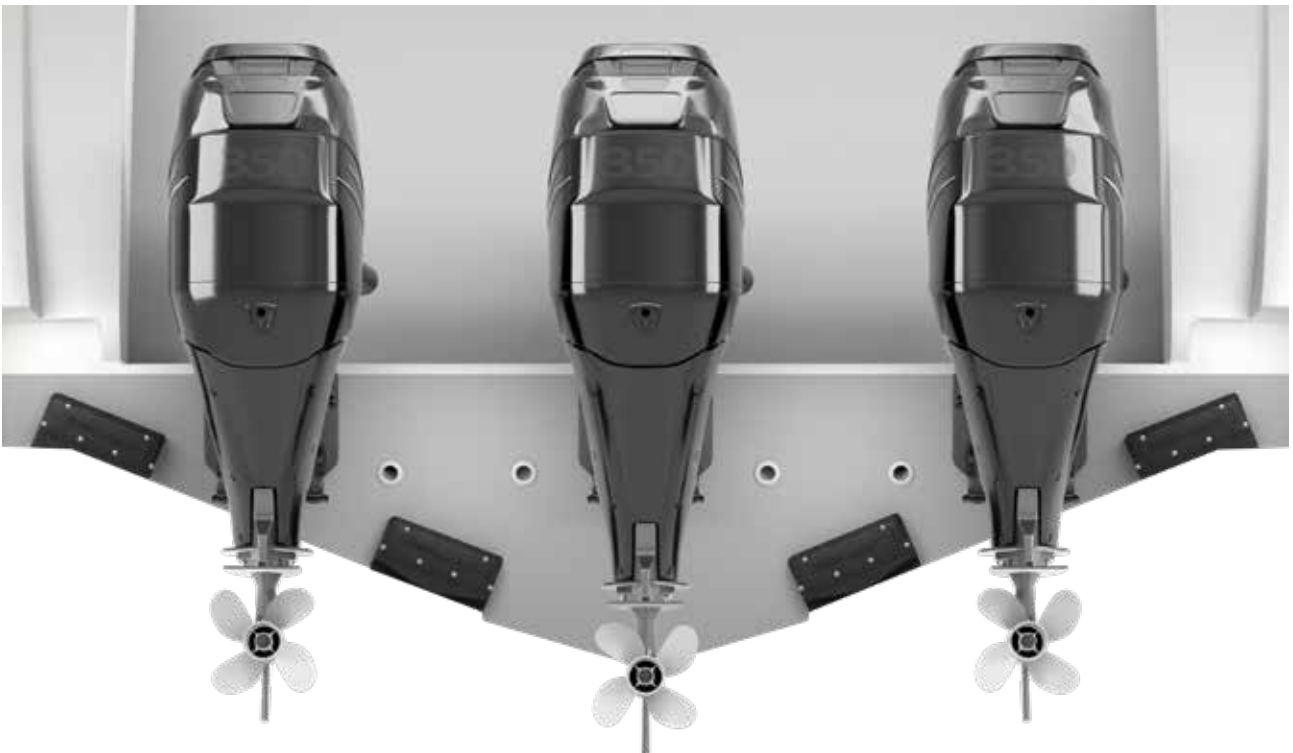

The modular design enables boat designers to develop their own novel applications, e.g. in multihulls or stepped hull high-speed craft.

## 6.1 FEATURES



- True outboard mount
- Modular design
- Fast actuation
- Straight, V-shaped, chine and intermediate models
- Integrated mounting plate
- Thru-hull fitting options
  - Above waterline
  - Concealed behind interceptor
- Submersible servo units
  - Brushless 12-24V DC servo motor
  - High-precision positioning
  - Calibration free
  - Durable and accessible
- Auto cleaning
  - Periodically selectable cleaning cycle
  - Prevents fouling inside the interceptor
- No corrosive materials

## 6.2 SPECIFICATIONS

Model	IT300-S	IT450-S	IT600-S	IT750-S	
<b>Length</b>	300 (11.8)	450 (17.7)	600 (24)	750 (29.5)	mm (in)
<b>Weight</b>	2.1 (4.6)	2.8 (6.2)	3.5 (7.7)	4.0 (8.8)	kg (lbs)

Model	IT450-S V13	IT450-S V16	IT450-S V19	IT450-S V22	
<b>Length</b>	450 (18)	450 (17.7)	450 (17.7)	450 (17.7)	mm (in)
<b>Weight</b>	3.2 (7.1)	3.3 (7.3)	3.4 (7.5)	3.5 (7.7)	kg (lbs)

Model	IT300-S CHINE PORT	IT300-S C CHINE STBD	IT450-S CHINE PORT	IT450-S CHINE STBD	
<b>Length</b>	300 (11.8)	300 (11.8)	450 (17.7)	450 (17.7)	mm (in)
<b>Weight</b>	2.2 (4.9)	2.2 (4.9)	2.9 (6.4)	2.9 (6.4)	kg (lbs)

Model	IT300-S INTER				
<b>Length</b>	300 (11.8)				mm (in)
<b>Weight</b>	2.4 (5.3)				kg (lbs)

<b>Max. boat speed</b>	60 knots
<b>Blade stroke</b>	30 mm (1.2 in)
<b>Blade rate</b>	20 mm/s (0.8 in/s)
<b>Thru-hull cable fitting</b>	Concealed or above waterline
<b>Servo actuator</b>	SU-S
<b>Cable length</b>	3 m (10 ft), extendable up to 6 m (20 ft)
<b>Cable material</b>	PUR
<b>Connector</b>	M12 5-pin circular
<b>Connector diameter</b>	14.5 mm (0.57 in)
<b>Supply voltage</b>	12 - 32 V DC
<b>Power consumption</b>	25 W max
<b>Operating temperature</b>	0° to +40°C (+32° to +104°F)
<b>Storage temperature</b>	-40° to +90°C (-40° to +194°F)
<b>Waterproof rating</b>	IP68 5 m (16 ft)
<b>Compliance</b>	CE, FCC

### 6.3 ORDERING DATA

Model	IT300-S	IT450-S	IT600-S	IT750-S
<b>Part No.</b>	2011232	2011233	2011234	2011235
Comes with Cable 3 m and Cable Covers				

- Included in kit boxes
- Available as an accessory
- Available as a spare part

Model	IT450-S V13	IT450-S V16	IT450-S V19	IT450-S V22
<b>Part No.</b>	2011482	2011483	2011484	2011485
Comes with Cable 3 m and Cable Covers				

- Available as an accessory
- Available as a spare part

Model	IT300-S CHINE PORT	IT300-S CHINE STBD	IT450-S CHINE PORT	IT450-S CHINE STBD
<b>Part No.</b>	2011702	2011703	2011704	2011705
Comes with Cable 3 m and Cable Covers				

- Included in kit boxes
- Available as an accessory
- Available as a spare part

Model	IT300-S INTER			
<b>Part No.</b>	2011701			
Comes with Cable 3 m and Cable Covers				

- Available as an accessory
- Available as a spare part

## 6.4 DIMENSIONS

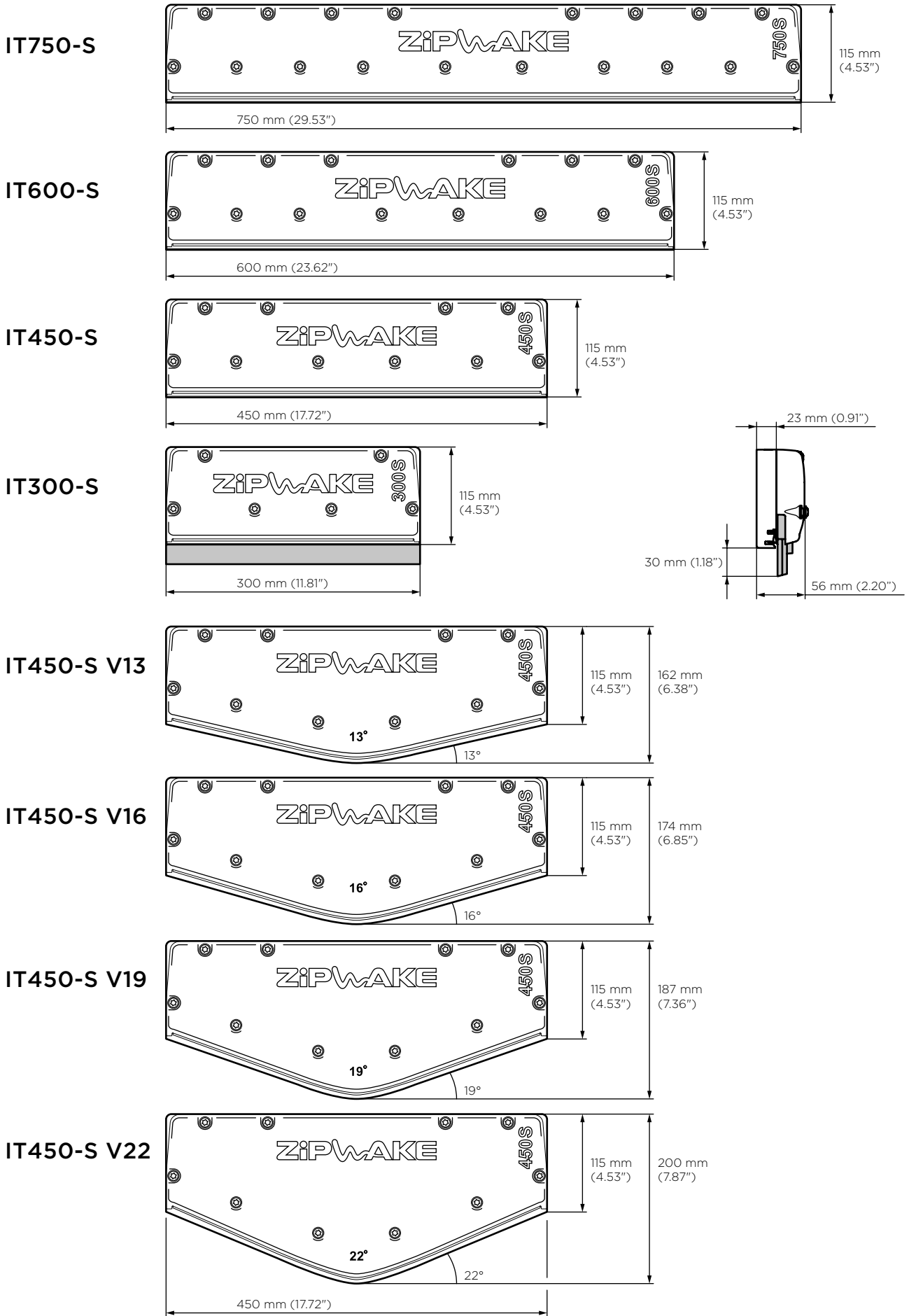

**IT450-S  
CHINE PORT**

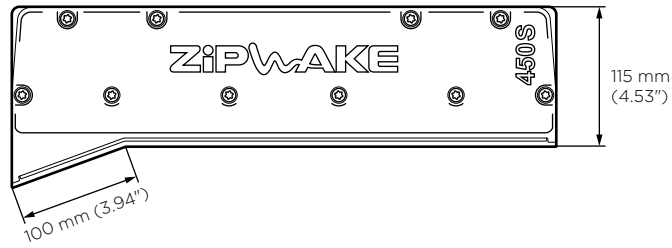

**IT450-S  
CHINE STBD**

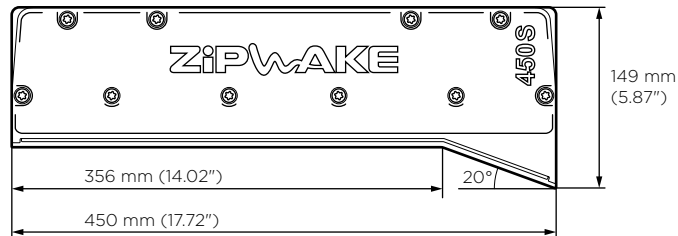

**IT300-S  
CHINE PORT**

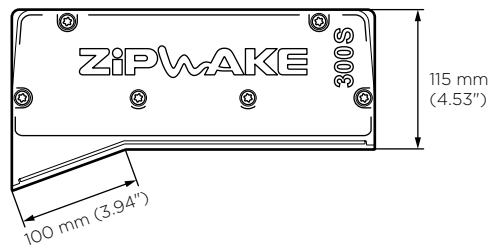

**IT300-S  
CHINE STBD**

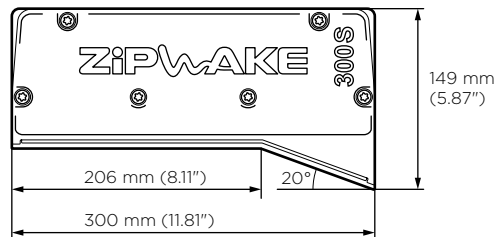

**IT300-S  
INTER**

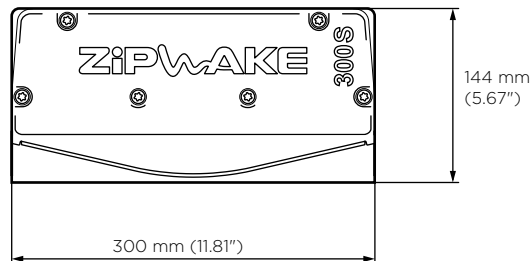

## 7 DISTRIBUTION UNIT

The distribution unit supplies the system with power and can accommodate up to six Series S interceptors.

The unit is connected to the main control panel or integrator module. It is robust, waterproof, oil resistant and ignition protected for mounting in an engine room. The power cable is included for easy connection to a battery. The distribution unit has built-in electrical protection, including its own protection fuse.



### 7.1 SPECIFICATIONS

<b>Model</b>	DU-S
<b>Supply voltage</b>	12 - 32 V DC
<b>Power consumption</b>	0.1 W max
<b>Protection fuse</b>	10 A ATO
<b>Power cable</b>	Length 4 m (13 ft), Diameter 9 mm (0.35 in), 12 AWG
<b>Operating temperature</b>	-20° to +85°C (-4° to +185°F)
<b>Storage temperature</b>	-40° to +90°C (-40° to +194°F)
<b>Waterproof rating</b>	IP67 with cables and/or protective caps mounted
<b>Oil resistance</b>	Common engine fluids
<b>Compliance</b>	CE, FCC, SAE J1171 Ignition Protected
<b>Weight</b>	0.9 kg (2 lbs) including the power cable

### 7.2 CONNECTORS

- Six interceptor connections
- I-BUS OUT (power and CAN bus to control panels or integrator module)
- 2-lead power cable

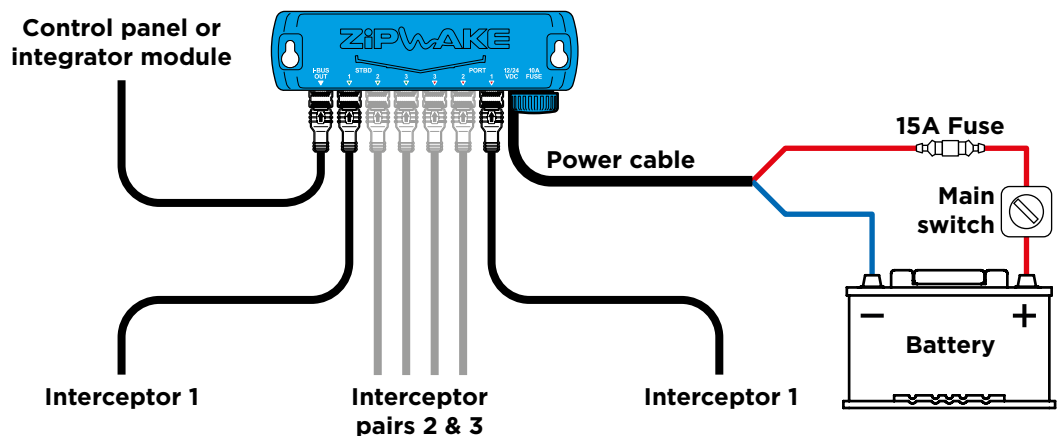



### 7.3 DIMENSIONS

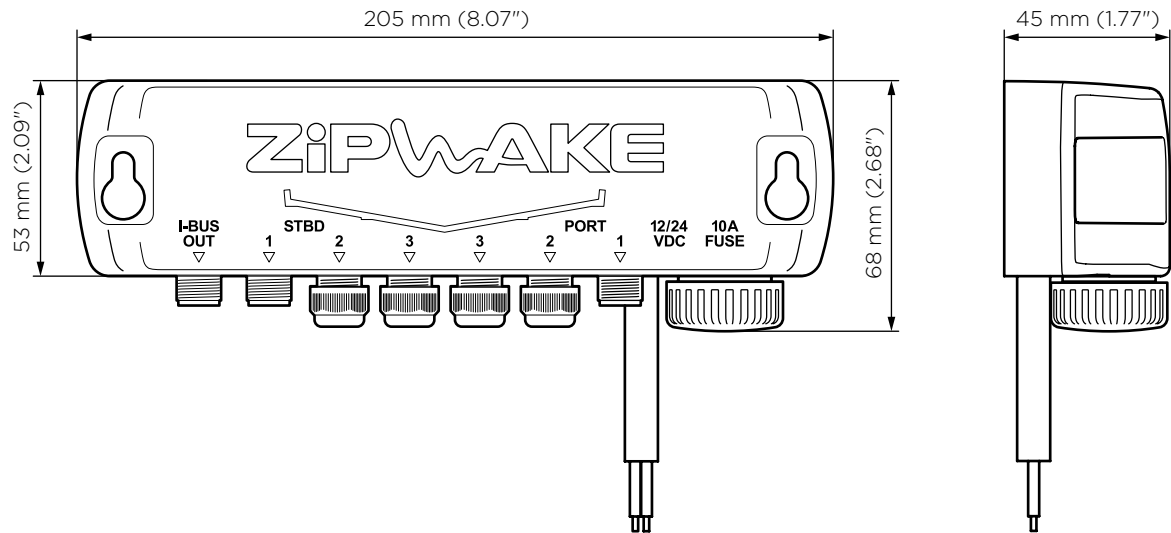

### 7.4 ORDERING DATA

<b>Model</b>	DU-S
<b>Part No.</b>	2011239 with Power Cable 4 m

- Included in kit boxes
- Available as an accessory
- Available as a spare part

## 8 CABLES

Model	Description
SC3-M12	Standard Cable 3 m (10 ft)
SC7-M12	Standard Cable 7 m (23 ft)
SC15-M12	Standard Cable 15 m (49 ft)
EC1.5-M12	Extension Cable 1.5 m (5 ft)
EC3-M12	Extension Cable 3 m (10 ft)
EC5-M12	Extension Cable 5 m (16 ft)
EC10-M12	Extension Cable 10 m (33 ft)
EC15-M12	Extension Cable 15 m (49 ft)
EC20-M12	Extension Cable 20 m (65 ft)



The standard cables are used to connect the main control panel or the integrator module to the distribution unit, usually located on or near the transom and also to connect an extra control panel or mini controller. The standard cables can be extended by using any of the available extension cables. The servo unit cable can be extended using 1.5 m or 3 m extension cables. The total servo cable length must not exceed 6 m (20 ft).

### 8.1 SPECIFICATIONS

Model	SC3-M12	SC7-M12	SC15-M12	EC1.5-M12	EC3-M12	EC5-M12	EC10-M12	EC15-M12	EC20-M12	
<b>Weight</b>	kg (lbs)	0.16 (0.35)	0.38 (0.84)	0.80 (1.76)	0.09 (0.2)	0.16 (0.35)	0.26 (0.57)	0.50 (1.1)	0.75 (1.65)	1.05 (2.31)
<b>Connectors</b>	M12 5-pin circular									
<b>Connector diameter</b>	14.5 mm (0.57 in)									
<b>Cable material</b>	PVC									
<b>Rated current</b>	4 A									
<b>Waterproof rating</b>	IP67 when connected									
<b>Operating temperature</b>	-20° to +85°C (-4° to +185°F)									
<b>Storage temperature</b>	-40° to +90°C (-40° to +194°F)									
<b>Oil resistance</b>	Common engine fluids									
<b>Compliance</b>	CE, FCC									

### 8.2 ORDERING DATA

Model	SC3-M12	SC7-M12	SC15-M12	EC1.5-M12	EC3-M12	EC5-M12	EC10-M12	EC15-M12	EC20-M12
<b>Part No.</b>	2012408	2011257	2012037	2011258	2011259	2011260	2011261	2012038	2012039

- Available as an accessory
- Available as a spare part

## 9 CONTROL PANEL ALU FRAME

The control panel for the Series E comes with a black frame and a wheel cap in a glossy, black chrome finish. A conversion kit is available for those who prefer a brushed aluminum finish. The kit includes simple instructions to make replacement an easy task.



### 9.1 SPECIFICATIONS

<b>Model</b>	CP ALU FRAME
<b>Surface appearance</b>	Brushed aluminum
<b>Items in kit</b>	1 x frame, 1 x wheel cap, 1 x instruction
<b>Weight</b>	0.03 kg (0.06 lbs)

### 9.2 ORDERING DATA

<b>Model</b>	CP ALU FRAME
<b>Part No.</b>	2011281

- Available as an accessory
- Available as a spare part

## 10 CONTROL PANEL COVER

Weather cover for the Series S control panel. Protects the display from the harsh marine environment when not in use. Fits standard surface mounted CP-S instrument. Available in five different colors to blend in with other instruments.



### 10.1 SPECIFICATIONS

<b>Model</b>	CP COVER
<b>Surface appearance</b>	Five different colors, soft-touch
<b>Weight</b>	0.05 kg (0.11 lbs)

### 10.2 ORDERING DATA

Model	CP COVER				
<b>Color</b>	<input type="checkbox"/> WHITE	<input type="checkbox"/> LIGHT GRAY	<input type="checkbox"/> MID GRAY	<input type="checkbox"/> DARK GRAY	<input type="checkbox"/> BLACK
<b>Part No.</b>	2011381	2011382	2011383	2011384	2011385

- Available as an accessory
- Available as a spare part

# 11 CONTROL PANEL GIMBAL BRACKET

When space is limited, the gimbal bracket provides a useful installation option for the Series S control panel. The gimbal bracket enables the control panel to be positioned at any angle between 0 and 360 degrees, and it comes with a cable gland that allows waterproof, open-sky installation.



## 11.1 SPECIFICATIONS

<b>Model</b>	GB
<b>Items in kit</b>	1 x bracket, 1 x frame, 10 x screws, 1 cable gland, 1 x instruction
<b>Weight</b>	0.12 kg (0.27 lbs)

## 11.2 DIMENSIONS

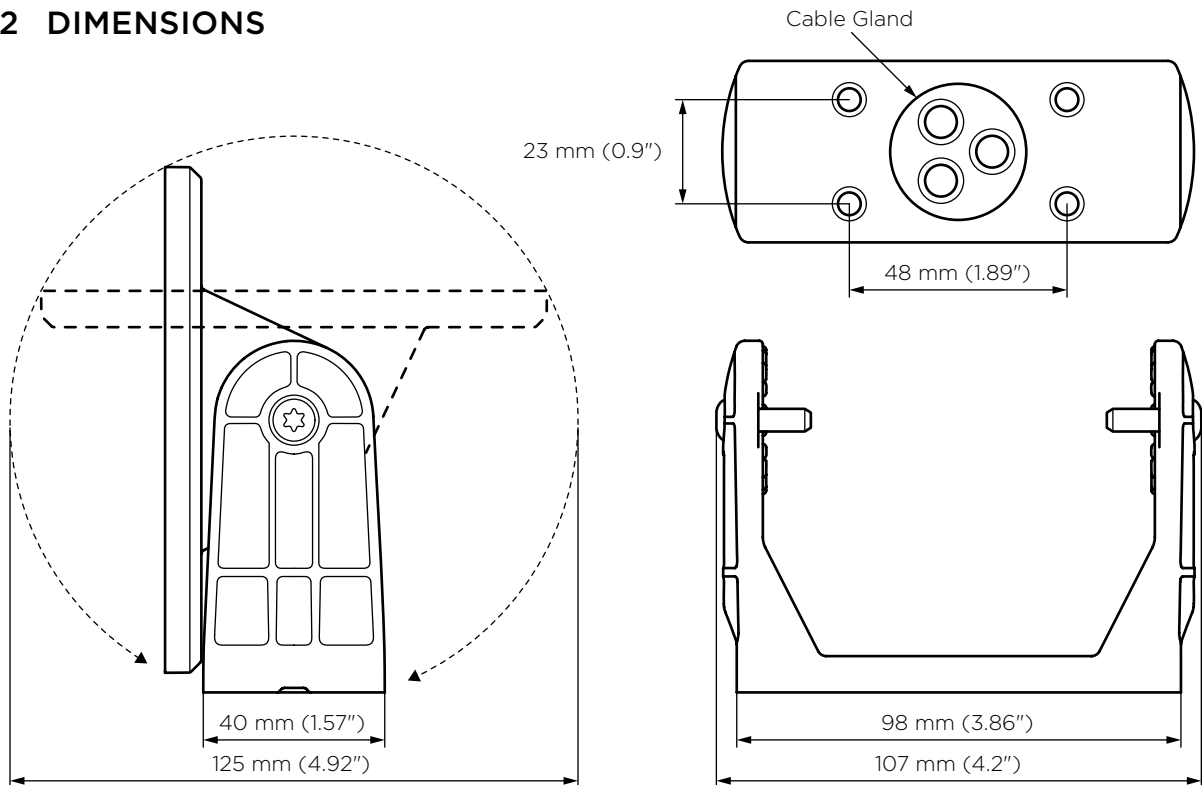

## 11.3 ORDERING DATA

<b>Model</b>	GB
<b>Part No.</b>	2011622

- Available as an accessory
- Available as a spare part

## 12 CABLE COVER

The thru-hull cable fitting of Series S interceptors can either be concealed behind the interceptor or positioned above the waterline. If the above-waterline mount is preferred, three parts are available to protect the cable: thru-hull cover, cable cover and a cable cover extension.

These parts are available as a cable cover kit to provide flexible routing of the cable on the transom.

### 12.1 SPECIFICATIONS

<b>Model</b>	CC-S
<b>Items in kit</b>	1 x thru-hull cover, 1 x cable cover 1 x cable cover extension 15 x screws
<b>Weight</b>	0.17 kg (0.37 lbs)

### 12.2 DIMENSIONS

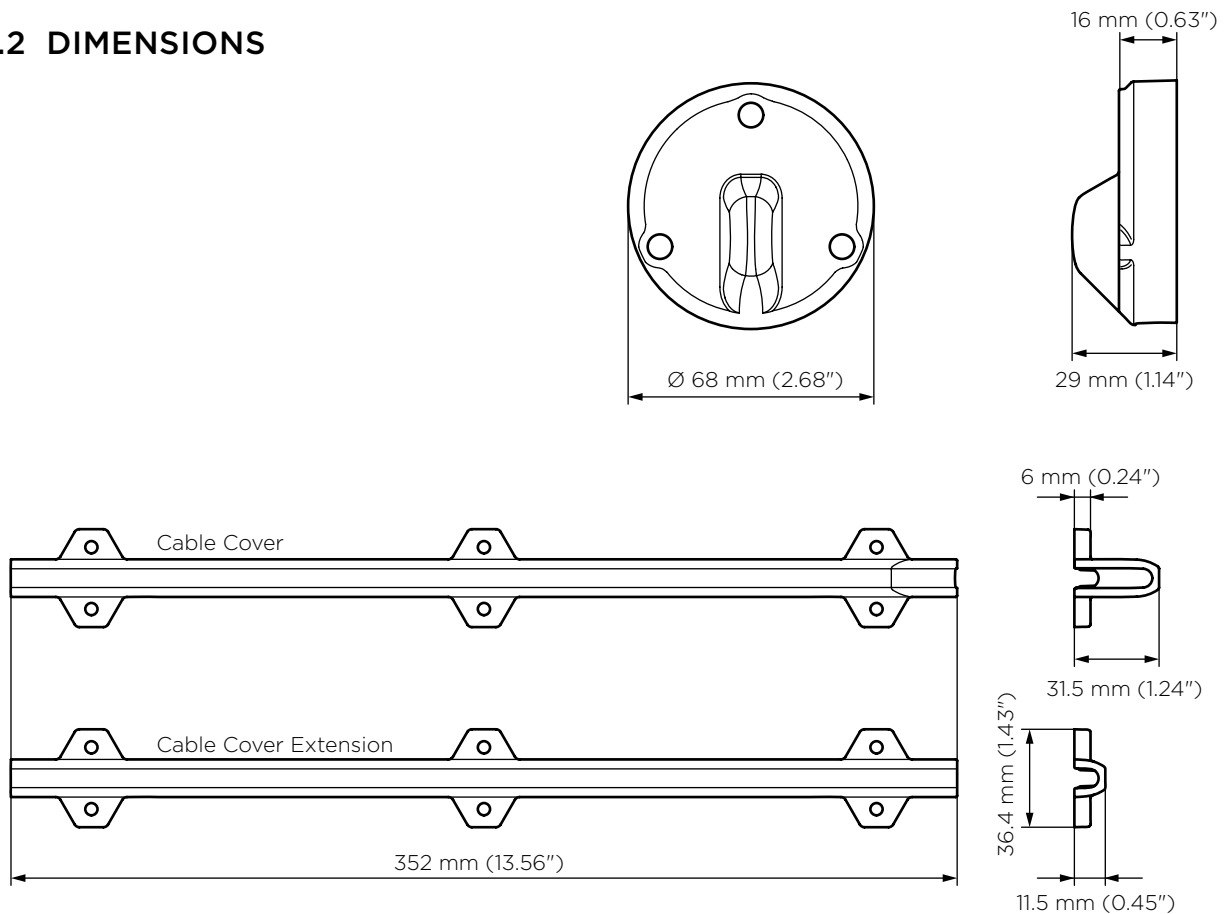

### 12.3 ORDERING DATA

<b>Model</b>	CC-S
<b>Part No.</b>	2011071 - Comes with each interceptor

- Available as an accessory
- Available as a spare part

## 13 SERVO UNIT

The Series S submersible electrical servo unit fits inside the interceptor, where it drives with precision the mechanism that provides linear motion to the interceptor blades. The unit is fast-acting, durable, calibration free and easy to install or replace. It comes with a rugged 3 m cable with a self-sealing thru-hull fitting.



### 13.1 SPECIFICATIONS

<b>Model</b>	SU-S
<b>Servo motor type</b>	Brushless DC with Hall sensors
<b>Supply voltage</b>	12 - 32 V DC
<b>Power consumption</b>	25 W max
<b>Operating temperature</b>	0° to +40°C (+32° to +104°F)
<b>Storage temperature</b>	-40° to +90°C (-40° to +194°F)
<b>Waterproof rating</b>	IP68 5 m (16 ft)
<b>Compliance</b>	CE, FCC
<b>Cable length</b>	3 m (10 ft), extendable up to 6 m (20 ft)
<b>Cable material</b>	PUR
<b>Connector</b>	M12 5-pin circular
<b>Connector diameter</b>	14.5 mm (0.57 in)
<b>Weight</b>	0.7 kg (1.5 lbs) including cable

### 13.2 ORDERING DATA

<b>Model</b>	SU-S
<b>Part No.</b>	2011230 with Cable 3 m

- Available as a spare part

## 14 INTERCEPTOR FRONTS

A front assembly comprises the interceptor's front housing, blade and assisting roller blade, the small parts that deal with blade linear motion and the set of screws required to mount the front to the back plate.



The front assemblies of the Series S interceptors have been designed to mitigate further damage to the interceptor in the rare event of contact with floating debris. Each interceptor model's front assembly is therefore available as a spare part.

### 14.1 SPECIFICATIONS

Refer to interceptor specifications in section 6.2.

### 14.2 DIMENSIONS

Refer to interceptor dimensions in section 6.4.

### 14.3 ORDERING DATA

Model	IT300-S FRONT	IT450-S FRONT	IT600-S FRONT	IT750-S FRONT
Part No.	2011252	2011253	2011254	2011255

- Available as a spare part

Model	IT450-S V13 FRONT	IT450-S V16 FRONT	IT450-S V19 FRONT	IT450-S V22 FRONT
Part No.	2011492	2011493	2011494	2011495

- Available as a spare part

Model	IT300-S CHINE PORT FRONT	IT300-S CHINE STBD FRONT	IT450-S CHINE PORT FRONT	IT450-S CHINE STBD FRONT
Part No.	2011742	2011743	2011744	2011745

- Available as a spare part

Model	IT300-S INTER FRONT
Part No.	2011741

- Available as a spare part

## 15 ADAPTOR PLATES

Zipwake adaptor plates are designed to minimize transom preparations required for upgrading to Zipwake Series S on boats already equipped with BTS interceptors and/or which have transoms with protruding bottom plates. The adaptor plates allow reuse of the existing screw hole pattern and they seal the previous holes for thru-hull fittings. Because the adaptor plates perfectly match the mounting holes, installation of the Zipwake Series S interceptors is completely straightforward. All that is needed on the transom are the new holes for the Zipwake thru-hull fittings.



### 15.1 SPECIFICATIONS

Model	AP300-S	AP450-S	
<b>Screw hole pattern</b>	BTS 300	BTS 450	
<b>Weight</b>	0.75 (1.65)	1.00 (2.20)	Kg (lbs)
<b>Items in kit</b>	2 x adaptor plates, 2 x o-rings, 16/24 x screws, 1 x instruction		
<b>Max. protrusion bottom plate</b>	15 mm (0.59 in)		
<b>Max. boat speed</b>	60 knots		
<b>Thru-hull cable fitting</b>	Concealed or above waterline		





## 15.2 DIMENSIONS

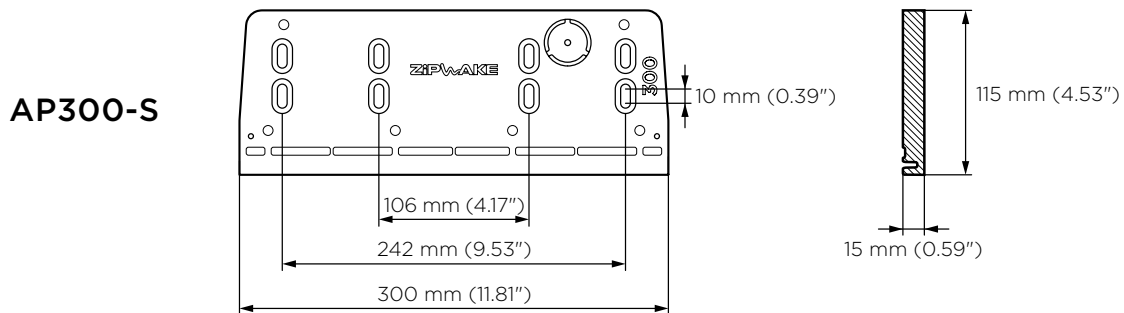
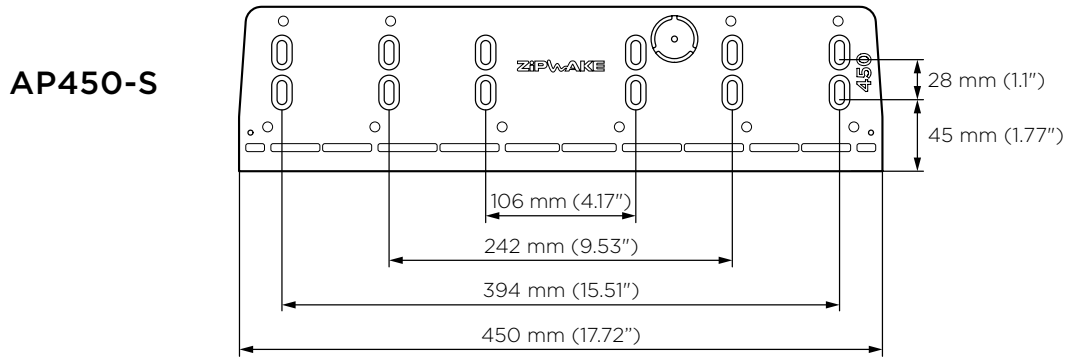

## 15.3 ORDERING DATA

Model	AP300-S	AP450-S
Part No.	2011585	2011586

- Available as an accessory
- Available as a spare part

## 16 EXTERNAL GPS ANTENNA

The Zipwake external GPS antenna is a 5Hz, 20-channel receiver with excellent reception that provides accurate and rapid vessel position and speed updates. Vessel speed is a necessary input for the Zipwake's automatic motion controller. The antenna has a rugged construction, is fully waterproof and can be mast or surface mounted on any vessel.



### 16.1 APPLICATION

The external GPS is optional and intended for use when no other strong GPS signal is available for the Zipwake system, e.g. when the vessel has just one helm station with a shielding top (canopy) and lacks other accessible GPS sources. In this case, the external GPS antenna is a good solution. Its 5 m cable can be extended up to 15 m using Zipwake extension cables. It connects easily to the connector marked EXT GPS on the back of the control panel. The external GPS can be connected to any control panel installed in the system.

### 16.2 SPECIFICATIONS

<b>Model</b>	GPU
<b>Connectors</b>	M12 5-pin circular
<b>Cable material</b>	White PVC
<b>Cable length</b>	5 m (16 ft) extendable to max 15 m (49 ft)
<b>Supply voltage</b>	5 V DC $\pm$ 5%
<b>Power consumption</b>	0.28 W, 55 mA (average)
<b>Protocol</b>	NMEA 0183 / RS232
<b>NMEA sentences</b>	RMC, VTG, GGA, GSA, GSV, GLL
<b>Baud rate</b>	38400
<b>Update rate</b>	5 Hz
<b>Number of channels</b>	20
<b>Average time to first fix</b>	Hot start 6 s, Warm start 38 s, Cold start 42 s
<b>Operating temperature</b>	-30° to +85°C (-22° to +185°F)
<b>Storage temperature</b>	-40° to +95°C (-40° to +203°F)
<b>Waterproof rating</b>	IP67
<b>Compliance</b>	CE, FCC
<b>Weight</b>	0.065 kg (0.14 lbs) without cable and connector
<b>Mounting</b>	Flush or pole

## 16.3 DIMENSIONS

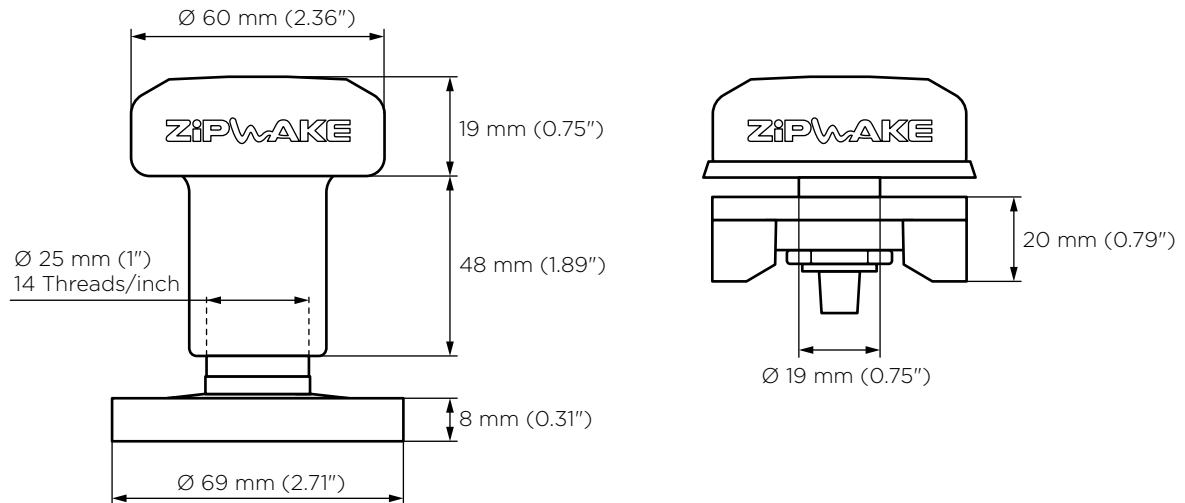

## 16.4 PIN OUT

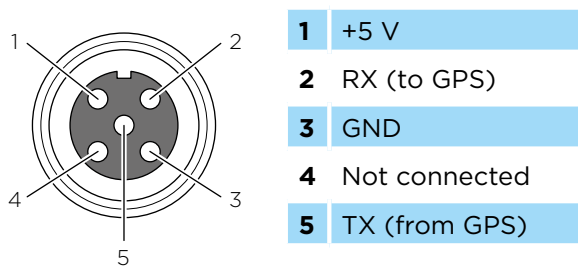

## 16.5 ORDERING DATA

<b>Model</b>	GPU
<b>Part No.</b>	2011240 with Cable 5 m and Mount Kit

- Available as an accessory
- Available as a spare part

# 17 WIRING DIAGRAMS

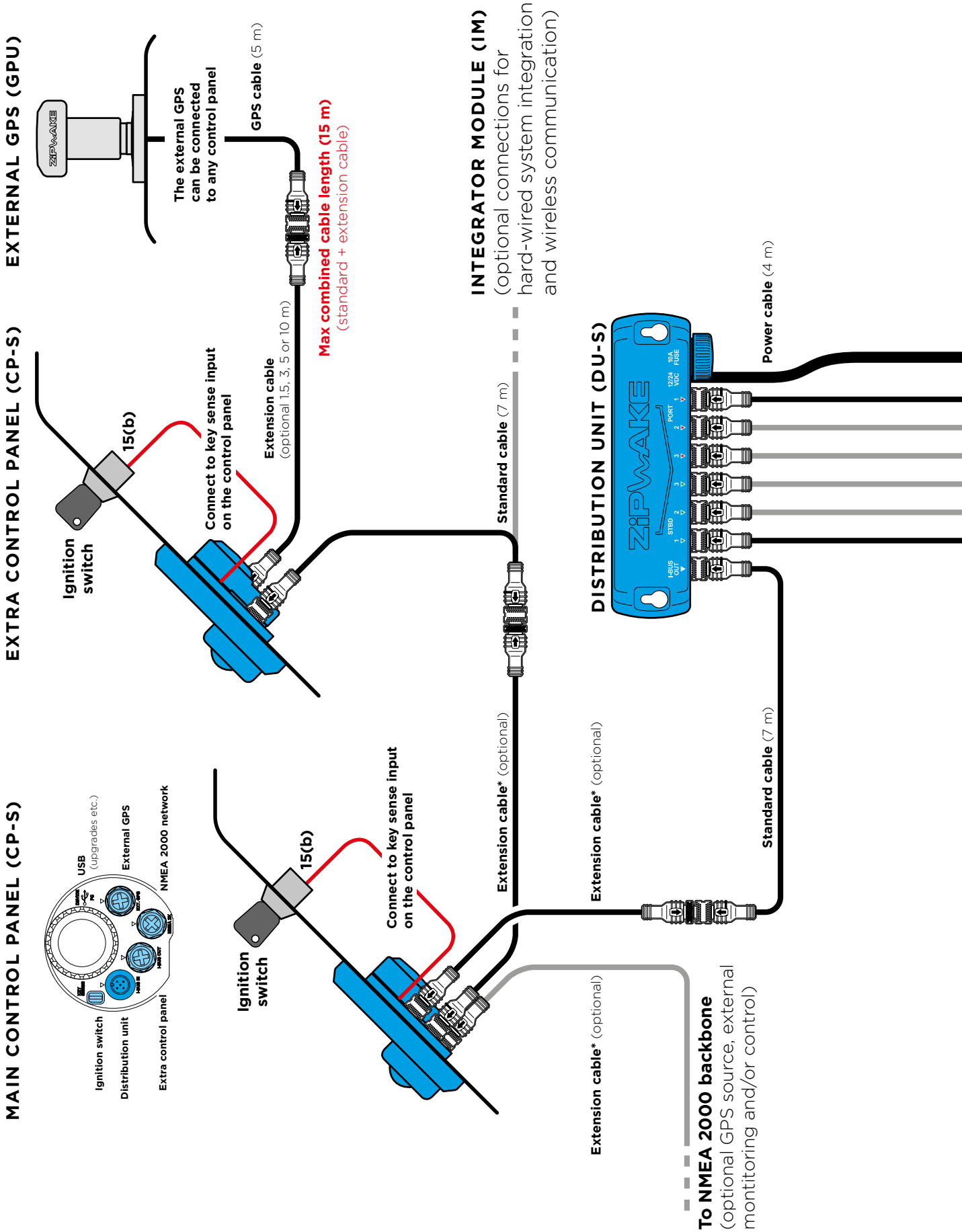

**\* Extension cable**

- (1.5 m)
- (3 m)
- (5 m)
- (10 m)
- (15 m)
- (20 m)

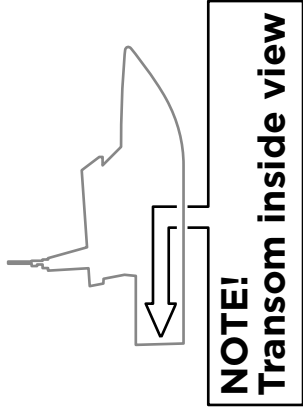

**Max combined cable length (6 m)**  
(standard + extension cable)

Extension cable (optional 1.5 or 3 m)

**STARBOARD**

(3 m)

(3 m)

(3 m)

(3 m)

(3 m)

(3 m)

**STARBOARD**

**Starboard  
Interceptor 2**

**Starboard  
Interceptor 3**

**Port  
Interceptor 3**

**Port  
Interceptor 2**

**Port  
Interceptor 1**

**PORT**

**POWER SUPPLY (12-32 V DC)**

**NOTE!** Do not use automatic thermal/magnetic fuse.

15A melting type fuse

**Main switch**

**Auto Cleaning**

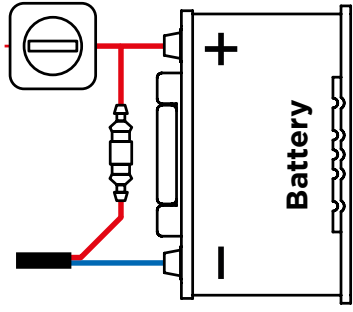
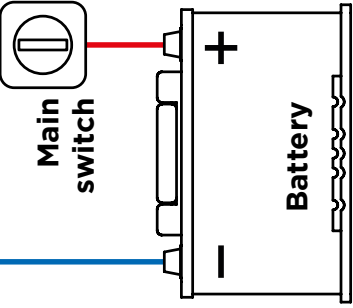

**NOTE!** Connect power directly to the positive battery terminal if interceptor **Auto Cleaning** will be used. Refer to the Operator's Manual on how to turn on the interceptor **Auto Cleaning** function.

**Optional:**  
Centerline mounted Series S  
interceptor connected to  
distribution unit port side 3

EXTERNAL GPS (GPU)

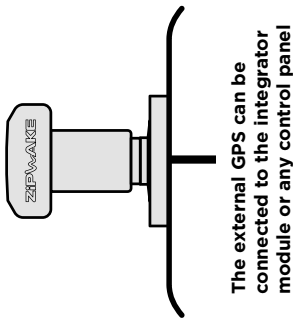

MULTIFUNCTION DISPLAY

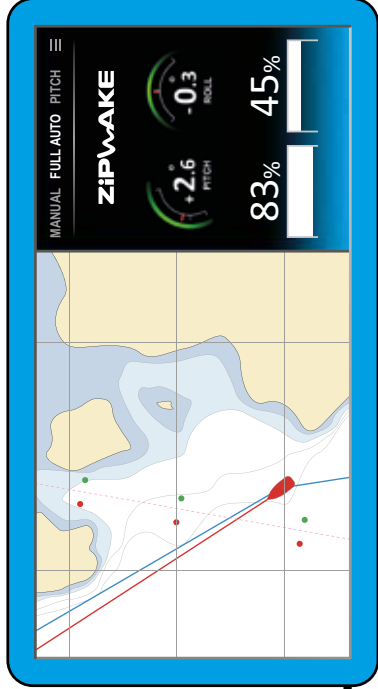

MOBILE DEVICE



Wi-Fi/  
Bluetooth

INTEGRATOR MODULE (IM)

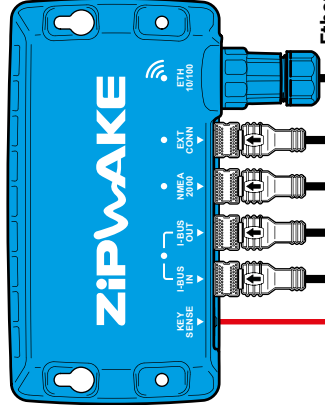

**Max combined cable length (15 m)**  
(standard + extension cable)

Extension cable (optional 1.5, 3, 5 or 10 m)

GPS cable (5 m)

**To NMEA 2000 backbone**  
(optional GPS source, external monitoring and/or control)

Extension cable\* (optional)

Extension cable\* (optional)

Extension cable\* (optional)

Ignition switch

**MINI CONTROLLER (MC)** (optional)

15(b)

Connect to Key Sense input on the mini controller

Standard cable (3 m)

- Additional control panels

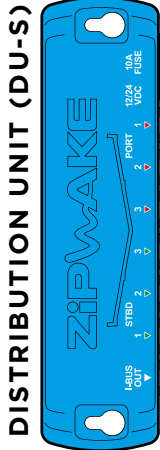

Power cable (4 m)

Standard cable (7 m)

Ignition switch

15(b)

Connect to Key Sense input on the integrator module

**\* Extension cable**

- (1.5 m)
- (3 m)
- (5 m)
- (10 m)
- (15 m)
- (20 m)

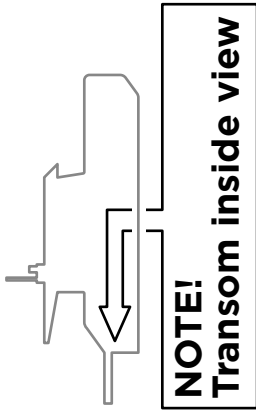

Extension cable (optional 1.5 or 3 m)

**Max combined cable length (6 m)**  
(standard + extension cable)

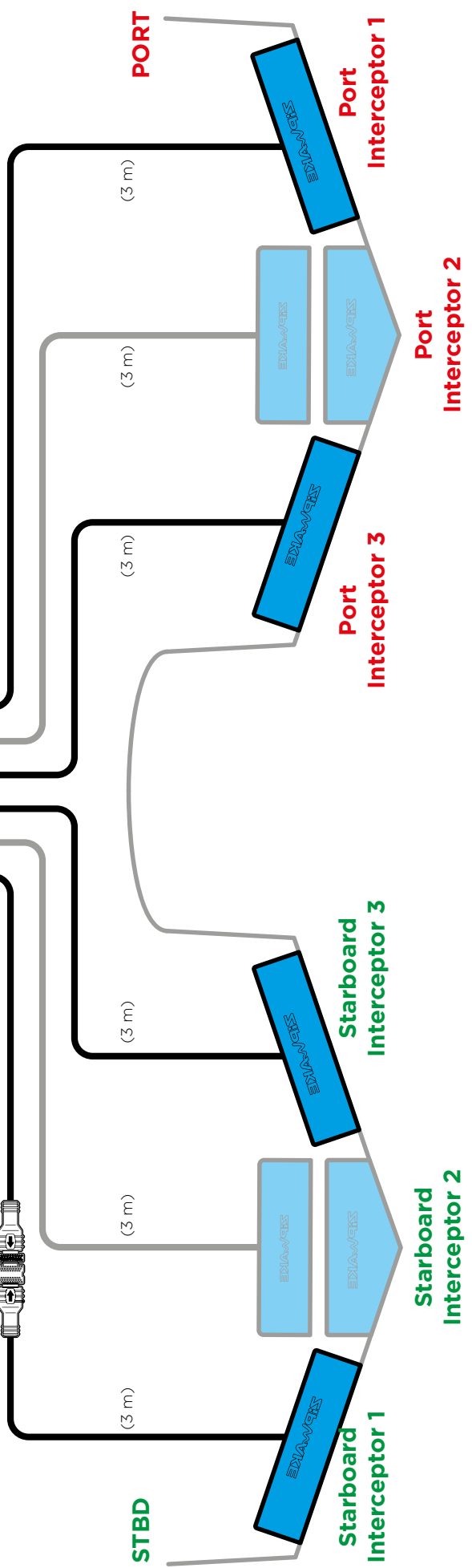
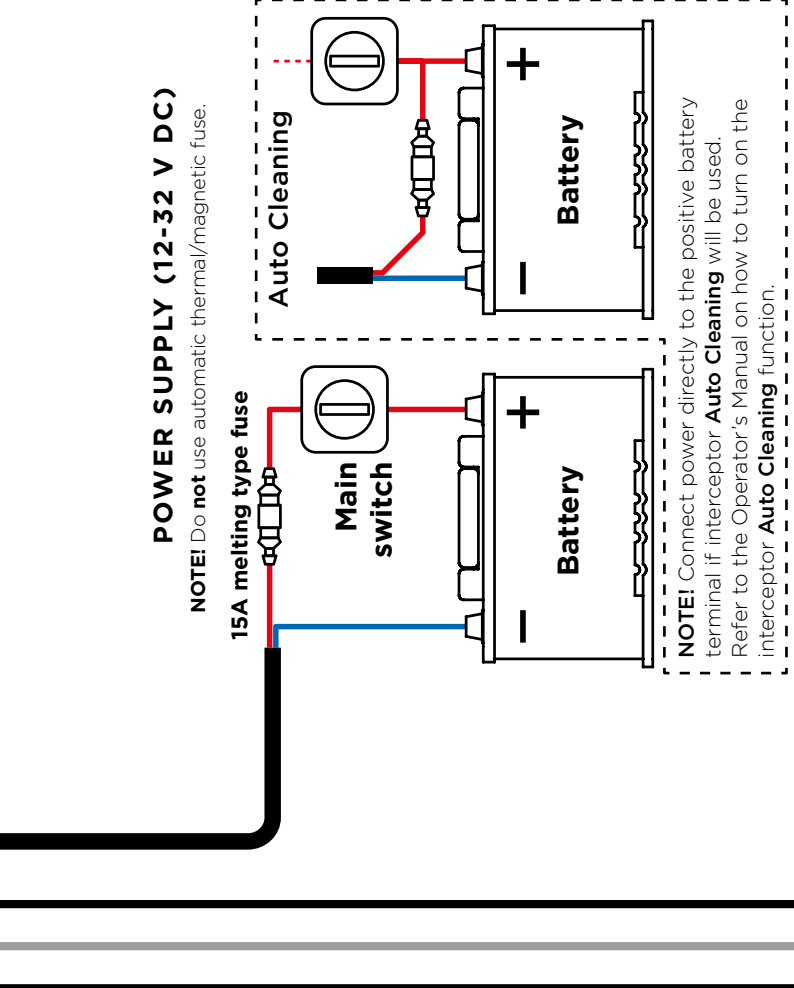



[zipwake.com](http://zipwake.com)